



Ascet 5K / 6K

Installation Manual
(Hardware)

SIH12005L052ACCU1B - Ascet 5K-110/1P2T2
SIH12006L062ACCU1B - Ascet 6K-135/1P2T2

Manual de Instalare
(Hardware)



579.45.25.0

Before using this product, carefully read all product documentation and retain it for future reference.

Content

Forward	1
Symbol Conventions	2
1. Safety	2
1.1 Symbols Used	3
1.2 Safety Precaution	3
2. Product Introduction	5
2.1 Overview	5
2.2 Product Appearance	6
2.2.1 Dimensions	6
2.2.2 General Description	7
2.3 Model Definition	8
3. Installation	8
3.1 Packing List	8
3.2 Selecting the Mounting Location	9
3.2.1 Installation Environment Requirements	9
3.2.2 Mounting Requirements	9
3.2.3 Installation Space Requirements	10
3.3 Mounting	10
4. Electrical Connection	12
4.1 Inverter's setup connection	12
4.2 Grounding	21
4.3 Grid/Backup/GEN Connection	22
4.3.1 BACKUP Connection	23
4.3.2 GEN Connection	25
4.4 Battery Connection	26
4.5 PV Connection	28
4.6 Meter/CT Connection	30
4.6.1 BMS Connection for Lithium Battery	31
4.6.2 DRMs Connection	35
4.6.3 RS485/Meter/CT Connection	36
4.6.3.1 RS485 Connection	37
4.6.3.2 CT Connection	39
4.6.3.3 Meter Connection	42
4.6.3.4 CT+Meter Connection	45
4.6.4 DI/DO/NTC/RSD Connection	47
4.6.5 Parallel Communication Connection	50
4.6.6 DRMs Connection	52
4.6.7 WIFI/LAN Module Connection	54
5. System Operation	55
5.1 Inverter Working Mode	55

5.1.1 Self consumption mode.....	55
5.1.2 Feed-in Priority Mode.....	57
5.1.3 Forced Charge/Discharge Function.....	59
5.1.4 Back-up Mode.....	59
5.1.5 Off Grid Mode.....	59
5.2 Startup/Shutdown the System.....	63
5.2.1 Startup the System.....	64
5.2.2 Shutdown the System.....	65
6. Commissioning.....	66
6.1 Inspection.....	66
6.2 Commissioning Procedure.....	66
7. User Interface.....	67
7.1 LED.....	67
7.2 LED Introduction.....	67
8. Maintenance.....	68
8.1 Routine Maintenance.....	68
8.2 Inverter Troubleshooting.....	69
8.3 Removing the Inverter.....	77

Cuprins

Introducere.....	79
Simboluri de siguranta.....	80
1. Masuri de siguranta.....	80
1.1 Simboluri utilizate.....	81
1.2 Precautii de siguranta.....	81
2. Prezentare produs.....	83
2.1 Notiuni generale.....	83
2.2 Descriere produs.....	84
2.2.1 Dimensiuni.....	84
2.2.2 Descriere generala.....	85
2.3 Definitie model.....	86
3. Instalarea.....	87
3.1 Verificarea ambalajului.....	87
3.2 Selectarea locatiei de instalare.....	87
3.2.1 Selectarea locatiei de instalare.....	87
3.2.2 Cerinte pentru pozitia de instalare.....	88
3.2.3 Cerinte pentru pozitia de instalare.....	88
3.3 Instalarea.....	89
4. Conexiunile electrice.....	91
4.1 Schema de conectare a invertorului.....	91
4.2 Impamantarea.....	100

4.3	Conectarea la retea/Backup/GEN.....	101
4.3.1	Conexiune BACKUP	102
4.3.2	Conexiune GEN	104
4.4	Conectarea bateriilor.....	105
4.5	Conectarea panourilor PV.....	107
4.6	Conexiuni interfata de comunicare.....	109
4.6.1	Conexiune BMS (doar pentru baterii Litium)	110
4.6.2	Conexiune DRM	114
4.6.3	Conexiune senzor CT/RS485/Contor	115
4.6.3.1	Conexiune RS485	116
4.6.3.2	Conexiune CT	118
4.6.3.3	Conexiune contor.....	121
4.6.3.4	CT+Conectare contor	124
4.6.4	Conexiuni DI/DO/NTC/RSD	126
4.6.5	Conectarea comunicarii in paralel	129
4.6.6	Conexiune DRM	131
4.6.7	Conectarea modului WIFI/LAN	134
5.	Operarea Sistemului	135
5.1	Mod de functionare	135
5.1.1	Mod consum propriu (Self consumption mode)	135
5.1.2	Modul de prioritate alimentare retea (Feed-in priority mode)	136
5.1.3	Funcție de incarcare/descarcare fortata - control bazat pe timp	138
5.1.4	Modul de rezerva (Back-up mode)	139
5.1.5	Modul Fara retea (Off Grid Mode).....	141
5.2	Pornirea/Oprirea sistemului	143
5.2.1	Procedura de pornire.....	143
5.2.2	Oprirea sistemului	144
6.	Punerea in functiune	146
6.1	Inspectia.....	146
6.2	Procedura de punere in functiune.....	146
7.	Interfata utilizatorului	147
7.1	LED.....	147
7.2	Descriere afisaj luminos.....	147
8.	Mentenanța	148
8.1	Mentenanța de rutina.....	148
8.2	Depanare invertor.....	149
8.3	Dezinstalarea invertorului	155

Please read this manual before using the product.

This user manual introduces the inverter in terms of its installation, electrical connections, operation, commissioning, maintenance, and troubleshooting. Please read through the manual carefully before installing and using the inverter, and keep the manual well for future reference.

Preface

About This Manual





This manual describes the installation, connection, the use of APP, commissioning and maintenance etc. of hybrid inverter. Please first read the manual and related documents carefully before using the product and store it in a place where installation, operation and maintenance personnel can access it at any time. The illustration in this user manual is for reference only. This user manual is subject to change without prior notice.

Target Group

hybrid inverters must be installed by professional electrical engineers who have obtained relevant qualifications.

Symbol Conventions

The following safety instructions and general information are used within this user manual.

Symbol	Description
 DANGER	Indicates an imminently hazardous situation which, if not correctly followed, will result in serious injury or death.
 WARNING	Indicates a potentially hazardous situation which, if not correctly followed, could result in serious injury or death.
 CAUTION	Indicates a potentially hazardous situation which, if not correctly followed, could result in moderate or minor injury.
 NOTICE	Indicates a potentially hazardous situation which, if not correctly followed, could result in equipment failure, or property damage.
 NOTE	Calls attention to important information, best practices and tips: supplement additional safety instructions for your better use of the PV inverter to reduce the waste of your resource.









1 Safety

Before using the inverter, please read all instructions and cautionary markings on the unit and manual.

Put the instructions where you can take them easily.

The hybrid inverter of ours strictly conforms to related safety rules in design and test. Local safety regulations shall be followed during installation, operation and maintenance. Incorrect operation work may cause injury or death to the operator or a third party and damage to the inverter and other properties belonging to the operator or a third party.

1.1 Symbols Used

Symbol	Description
	Danger of high voltage and electric shock! Only qualified personnel may perform work on the inverter.
	Danger of high voltage. Residual voltage in the inverter need 5 mins to discharge, wait 5 mins before operation.
	Danger of hot surface
	Do not disconnect under load, otherwise there will be a danger of fire.
	Environmental Protection Use Period
	Refer to the operating instructions
	Product should not be disposed as household waste
	Grounding terminal

1.2 Safety Precaution

- Installation, maintenance and connection of inverters must be performed by qualified personnel, in compliance with local electrical standards, wiring rules and requirements of local power authorities and/or companies
- To avoid electric shock, DC input and AC output of the inverter must be terminated at least 5 minutes before performing any installation or maintenance.
- The temperature of some parts of the inverter may exceed 60° during operation. To avoid being burnt, do not touch the inverter during before touching it.

- Ensure children are kept away from inverters.
- Don't open the front cover of the inverter. A part from performing work at the wiring terminal (as instructed in this manual), touching or changing components without authorization may cause injury to people, damage to inverters and annulment of the warranty
- Static electricity may damage electronic components. Appropriate method must be adopted to prevent such damage to the inverter; otherwise the inverter may be damaged and the warranty annulled.
- Ensure the output voltage of the proposed PV array is lower than the maximum rated input voltage of the inverter; otherwise the inverter may be damaged and the warranty annulled.
- When exposed to sunlight, the PV array generates dangerous high DC voltage. Please operate according to our instructions, or it will result in danger to life.
- PV modules should have an IEC61730 class A rating.
- If the equipment is used in a manner not specified by the manufacturer, the protection provided by the equipment may be impaired.
- Completely isolate the inverter before maintaining. Completely isolate the inverter should: Switch off the PV switch, disconnect the PV terminal, disconnect the battery terminal, and disconnect the AC terminal.
- Prohibit to insert or pull the AC and DC terminals when the inverter is running.
- Don't connect hybrid inverter in the following ways: Backup Port should not be connected to grid, The single PV panel string should not be connected to two or more inverters.

2 Product Introduction

2.1 Overview

Hybrid Inverter

The hybrid inverters are high-quality inverter which can convert solar energy to AC energy and store energy into battery.

The inverter can be used to optimize self consumption, store in the battery for future use or feed into public grid. Work mode depends on PV energy and user's preference. It can provide power for emergency use during the grid lost by using the energy from battery and inverter (generated from PV).

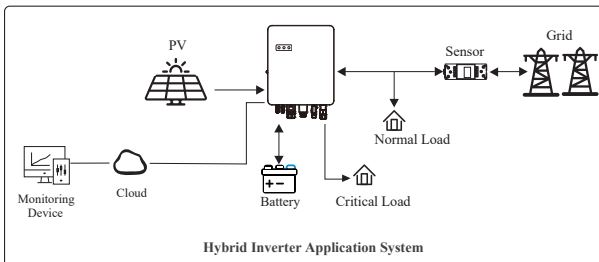

Declaration for Off-grid Function

The following statement involves our company general policies about the hybrid inverters described in this document.

For hybrid inverters, the electrical installation typically includes connection of the inverter to both PV modules and batteries. If there is no available power from batteries or PV modules in off-grid mode, the backup power supply will be automatically terminated. Our company shall hold no liability for any consequences arising from failing to observe this instruction.

Normally, the Back-Up switching time is less than 10 ms. However, some external factors may cause the system to fail on off-grid mode. Therefore, the users must be aware of conditions and follow the instructions as below: Do not connect loads that are dependent on a stable energy supply for a reliable operation.

Do not connect the loads whose total capacity is greater than the maximum Back-Up capacity.

Do not connect the loads that may cause very high start-up current surges, such as air conditioner, high-power pump, vacuum cleaner, and hair drier.

Due to the condition of the battery itself, battery current might be limited by some factors, including but not limited to the temperature and weather.

Declaration for Off-grid Overload Protection

The inverter will restart in case of overload protection. The time required for restarting will be 3 min if overload protection repeats. After the cumulative overload times up to three, the inverter will be locked. You can unlock the inverter by holding the button for 1s to clear the overload alarm. Try to reduce Back-Up load power within maximum limitation or remove the loads which may cause very high start-up current surges.

2.2 Product Appearance

2.2.1 Dimensions

Natural cooling model:
Ascet 5K-110

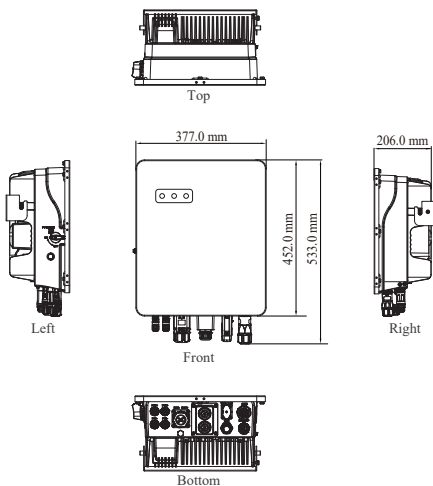

Fan cooling model:
Ascet 6K-135

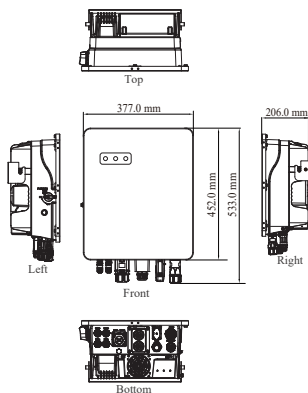

2.2.2 General Description

In the following narration we will talk about the Ascet 6K-165 model.

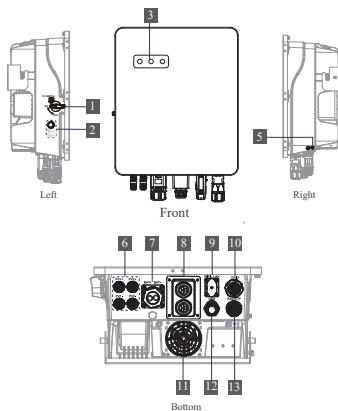

Number	Description
1	PV switch
2	PV switch
3	LED indicator
5	Grounding port
6	PV connection port
7	Battery connection port
8	Communication port
9	WIFI/LAN port
10	Grid connection port
11	External fan used in certain models, Ascet 6K-135 for example
12	GEN connection port
13	BACKUP connection port

2.3 Model Definition

The letters in the product model have the specific informations.
(Take SIH12005L052ACCU1B - Ascet 5K-110/1P2T2 as example.)

SIH12005L052ACCU1B

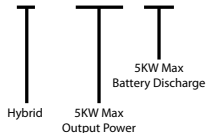

3 Installation

3.1 Packing List

"Product box contain will be show in an individual paper in the box. Please check the packing list paper for more information and the component assigned."

3.2 Selecting the Mounting Location

3.2.1 Installation Environment Requirements

- a. With an IP65 protection rating, the inverter can be mounted indoors or outdoors.
- b. The mounting location must be inaccessible to unrelated personnel since the enclosure and heat sinks are extremely hot during operation.
- c. Do not install the storage inverter in areas containing highly flammable materials or gases.
- d. To ensure optimum operation and long service life, the ambient temperature must be below 50°C.
- e. The inverter must be mounted in a well ventilated environment to ensure good heat dissipation.
- f. Please avoid direct sunlight, rain exposure, snow lay up install.
- g. The carrier where the inverter is mounted must be fire-proof. Do not mount the inverter on flammable building materials.
- h. Do not install the inverter in a rest area since it will cause noise during operation.
- i. The installation height should be reasonable and make sure it is easy to operate and view the display.
- j. Product label and warning symbols shall be clear to read after installation.
- k. To ensure long service life, the storage inverter must not be exposed to direct solar irradiation, rain, or snow. It is recommended that the inverter be mounted in a sheltered place.

3.2.2 Mounting Requirements

Mount the inverter vertically or tilted backward by max 15°. The device can not be installed in the wrong mode and the connection area must point downward.

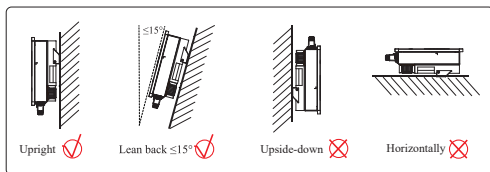

3.2.3 Installation Space Requirements

To ensure the inverter normally and easy to operate, there are requirements on available spaces of the inverter, e.g. to keep enough clearance. Refer to the following figures.

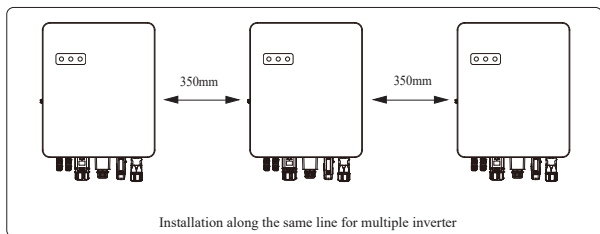
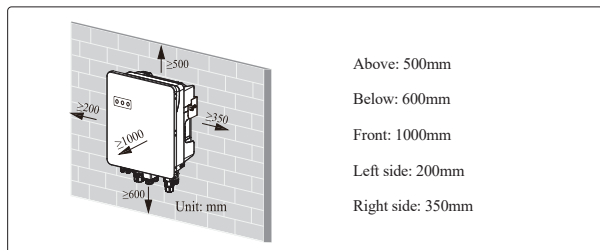

3.3 Mounting

Before mounting the inverter, you have to prepare the expansion bolts. (specification: M12*80; quantity: 3 - will be founded inside the box).

Step 1. Install the mounting bracket

1. Use a level ruler to mark the position of the 3 holes on the wall. Refer to Figure a. and drill 3 holes, 16mm in diameter and 55mm in deep. Refer to Figure b.
2. Use a hammer to tap the expansion bolt kit into the hole. Refer to Figure c.

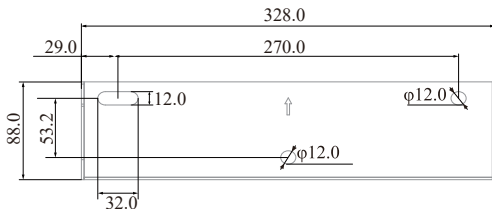

Unit: mm

NOTE!

- Do not remove the nut unit in this step.
- Before taping the expansion bolt kit into the hole, you need to tighten the bolt with an extra 1-2 turns to prevent dust accumulation.

3. After tightening 2-3 buckles, the expansion bolts are tight and not loose, and then unscrew the bolts, spring washer, gasket. Refer to Figure c.

4. Install and fix the mounting bracket on the wall. Refer to Figure d.

Step 2. Install the inverter on the mounting bracket. Then lock the inverter using the security screw. Refer to Figure d.

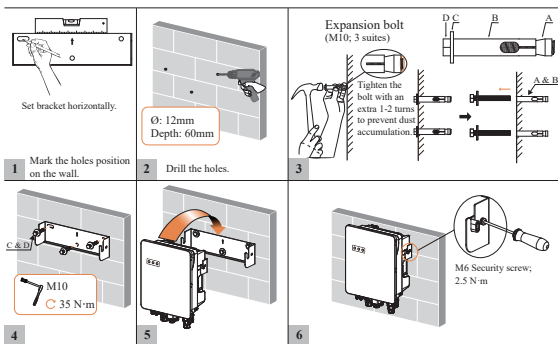

Danger

Before drilling the hole on the wall, ensure no damage on the electric wire and/or water pipe inside the wall.

CAUTION

To prevent potential damages and injuries from inverter falling down, please hang the inverter on the bracket, do not loosen grip unless confirm the inverter is well mounted.

4 Electrical Connection

4.1 Inverter's setup connection

This chapter shows the details connection of hybrid inverter. The following illustration only uses the hybrid inverters as an example.

Hybrid inverter system connection diagram:

Non-parallel connection mode

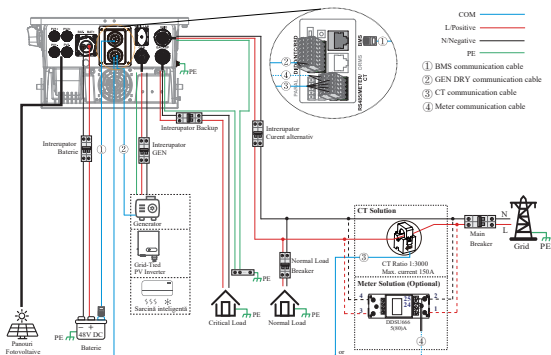

- ① BMS communication cable
- ② GEN DRY communication cable
- ③ CT communication cable
- ④ Meter communication cable

NOTE!

1. BMS connection is only for lithium battery.

2. Meter is optional.

3. About breakers:

DC breaker on BATTERY side: 5K: 150A, 6K: 175A

AC breakers on Critical load side and Smart load side $\geq 40A$

AC breaker on Inverter load side $\geq 50A$

DANGER

Ensure that inverter and all cables to be installed are completely powered off during whole installation and connection. Otherwise, fatal injury can occur due to the high voltage caused from AC and DC cables.

AC coupling connection wiring diagram

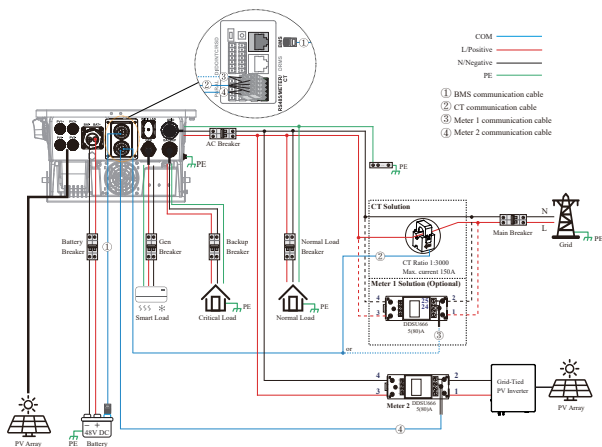

NOTE!

- When connecting the meter, the phase of the meter should be consistent with that of the inverter.
- Ensure that meter 1 and meter 2 are wired properly and correctly, otherwise unpredictable problems may occur.
- If the current flowing through the meter is too high, use CT+meter
- The CT, meter 1 and meter 2 communication terminal pin definition:

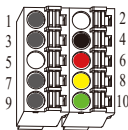

Pin	Function Description	Pin	Function Description
1	RS485_A1 (for Meter 1)	4	I_CT- (for CT)
3	RS485_B1 (for Meter 1)	6	I_CT+ (for CT)
7	RS485_A2 (for Meter 2)	8	+3.3V (for CT)
9	RS485_B2 (for Meter 2)	10	CT_DET (for CT)

App setting guide for AC Coupling Function

Step 1: Login as an administrator.

Step 2: Tap **Console** > **Hybrid Setting** > **Other** to enable AC coupling function and set meter 2.

Step 3: Tap **Console** > **Power limit** to set power control (meter 1) and select meter type. CT sensor is selected by default.

Parallel application ($2 \leq N \leq 9$)

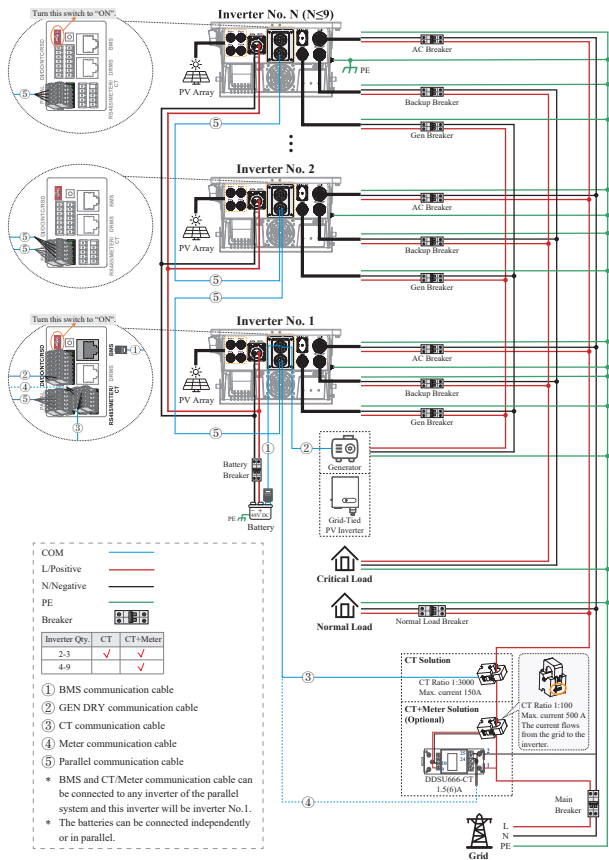

Note for Scheme A:

1. PV related contents are N/A for AC Couple inverter.
2. BMS communication connection is only for lithium battery.
3. It is necessary to turn the matched resistance switch of No. 1 inverter and No. N inverter to “ON” in parallel connection mode.
4. With parallel connection mode, it is necessary to connect APP to one of inverters and then go to Console > Other Setting page to enable Parallel mode on APP. Please refer to page 65.
5. In a parallel system, the smart load is only allowed to be connected to GEN port in a non-parallel way.
6. In one parallel system, the batteries can be connected independently or in parallel, the manual only shows the batteries connected in parallel. In one system connected with independent batteries, the CT/meter cable can be connected to any inverter of the parallel system and this inverter is the main inverter, i.e., Inverter No. 1.
7. For one parallel system, ensure the conductor’s materials, cross-sectional areas, and lengths of AC cables between Inverter No. 1 and other inverters of the system on the backup port are the same. It is recommended that the length of the cable be less than or equal to 2 m.
8. About breakers:
DC breaker on BATTERY side: 5K: 150A, 6K: 175A
AC breaker on Critical load side $\geq 40A$
AC breaker on Normal load side $\geq 50A$
AC breaker on Grid side $\geq 60A$



DANGER

Ensure that inverter and all cables to be installed are completely powered off during whole installation and connection. Otherwise, fatal injury can occur due to the high voltage caused from AC and DC cables.

AC coupling application of parallel system

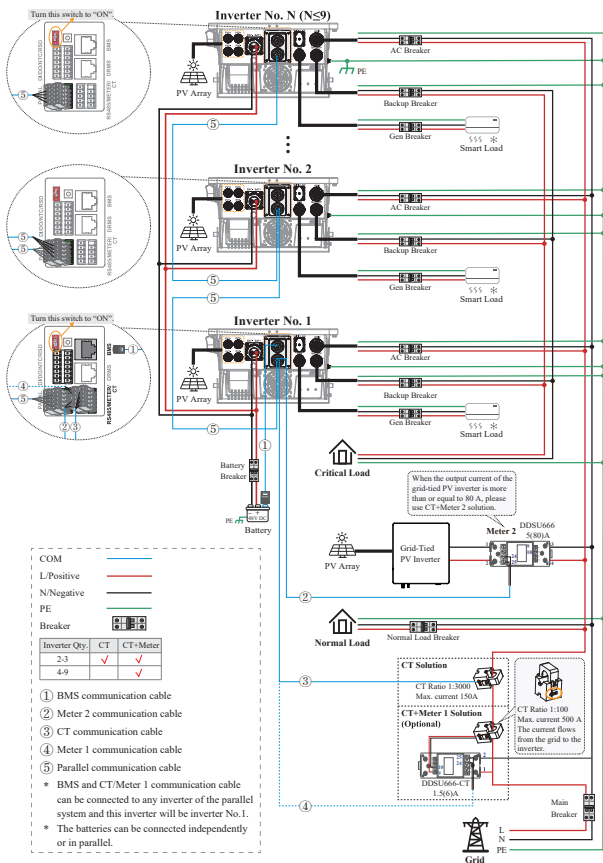

NOTE!

When connecting the meter, the phase of the meter should be consistent with that of the ESS/PV inverter.

- Ensure that meter 1 and meter 2 are wired properly and correctly, otherwise unpredictable problems may occur.
- If the current flowing through the meter is too high, use CT+meter
- The CT, meter 1 and meter 2 communication terminal pin definition:

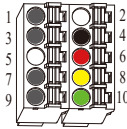

Pin	Function Description	Pin	Function Description
1	RS485_A1 (for Meter 1)	4	I_CT- (for CT)
3	RS485_B1 (for Meter 1)	6	I_CT+ (for CT)
7	RS485_A2 (for Meter 2)	8	+3.3V (for CT)
9	RS485_B2 (for Meter 2)	10	CT_DET (for CT)

App setting guide for AC Coupling Function

Step 1: Login as an administrator.

Step 2: Tap **Console** > **Hybrid Setting** > **Other** to enable AC coupling function and set meter 2.

Step 3: Tap **Console** > **Power limit** to set power control (meter 1) and select meter type. CT sensor is selected by default.

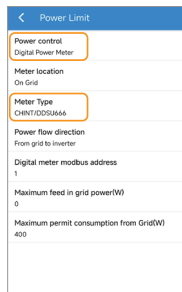
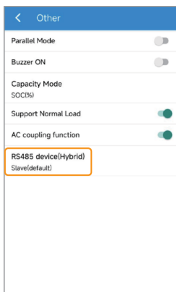
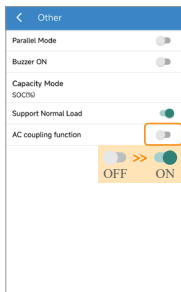

Three-phase Equipment Connection Wiring Diagram (N=3)

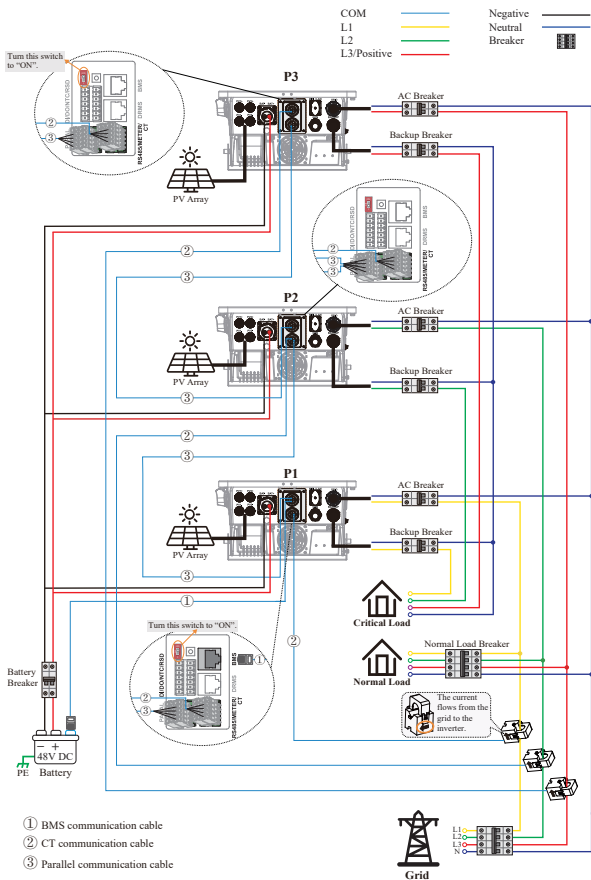

NOTE!

- Make sure all inverters in parallel have the same firmware version by verifying the 'Master DSP', 'Slave DSP', and 'CSB' version numbers on the app. It is recommended to restore the firmware before three-phase connection to ensure the same parameter for each inverter.
- A maximum of 3 single-phase inverters are connected to form a three-phase equipment and each inverter supports one phase only.
- BMS connection is only applicable to lithium battery.
 - For shared lithium battery connection, please refer to Three-phase equipment connection wiring diagram to connect the BMS communication cable.
 - For standalone lithium battery connection, the BMS communication cable should be connected to every inverter.

App setting guide for three-phase connection

Under three-phase connection mode, it is necessary to connect the app to each inverter and set related parameters. The following is an example for three inverters.

Step 1: Login as an administrator.

Step 2: Go to Console > Hybrid Setting > Other to enable parallel mode.

Step 3: Set the phase position accordingly: Go to Console > Hybrid Setting > Other > Set phase position. Notice that all three inverters should be set in this step. (Figure a-b)

Step 4: Set the battery connect type: Console > Hybrid Setting > Other > Parallel System Battery Connect Type > Select parallel/ independent battery.

Step 5: Set the other basic parameters of the inverter. Detailed setting process please refer to Quick Setup.

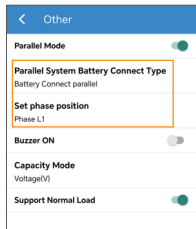

Figure a P1-Phase L1

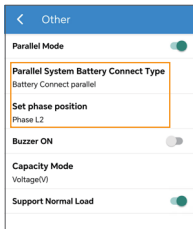

Figure b P2-Phase L2

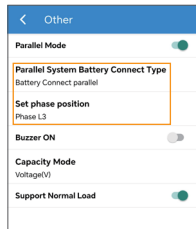
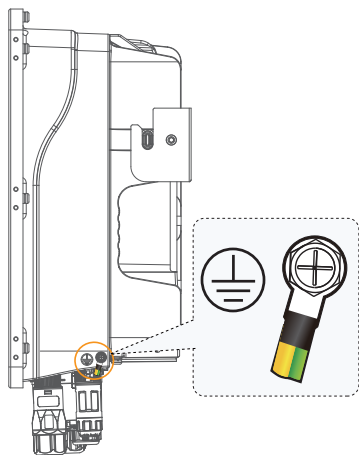

Figure c P3-Phase L3

4.2 Grounding

A protective earth (PE) terminal is equipped at the side of the inverter. Please be sure to connect this PE terminal to the PE bar for reliable grounding. AWG 10 or 12, yellow-green lines are recommended (screw: M4 x 10 mm; 1.2 N·m).



Right-side view

DANGER

The inverter must be grounded; otherwise, there may be electric shock risk.

CAUTION

If the positive pole or negative pole of the PV array is required to be grounded, then the inverter output (to AC grid) must be isolated by transformer in accordance with IEC62109-1, -2 standards.

4.3 GRID Connection

Before connecting the GRID terminal, ensure that both the AC terminal and the DC terminal are powered OFF and the PV switch is OFF. Otherwise there is a risk of high voltage shock.

GRID connection procedure:

Step 1: Select the cable.

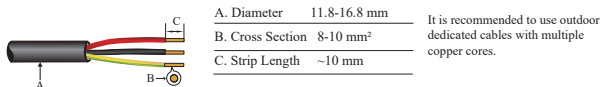

Step 2: Select the cable.

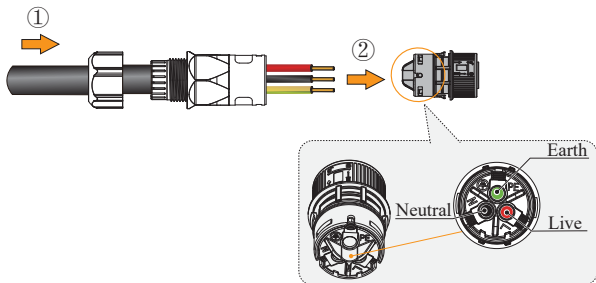

NOTE!

Remove the orange seal from the threaded sleeve if the wires do not pass through. If the wires still do not pass through, remove the blue seal.

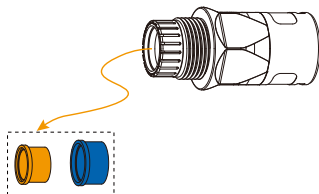

Step 3: Tighten three screws and ensure each screw cap does not exceed the surface.

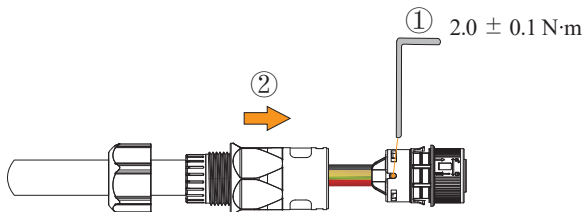

Step 4: Install the connector to the “GRID” port.

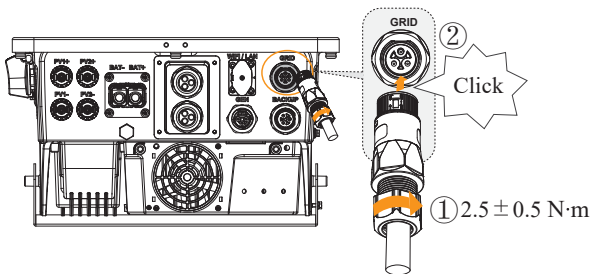

4.3.1 BACKUP Connection

Before connecting the BACKUP terminal, ensure that both the AC terminal and the DC terminal are powered OFF and the PV switch is OFF. Otherwise there is a risk of high voltage shock.

BACKUP connection procedure:

Step 1: Select the cable.

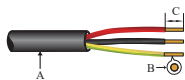

A. Diameter 11.5-13.5 mm

B. Cross Section 5.3-6 mm²

C. Strip Length ~10 mm

It is recommended to use outdoor dedicated cables with multiple copper cores.

Step 2: Thread the cable.

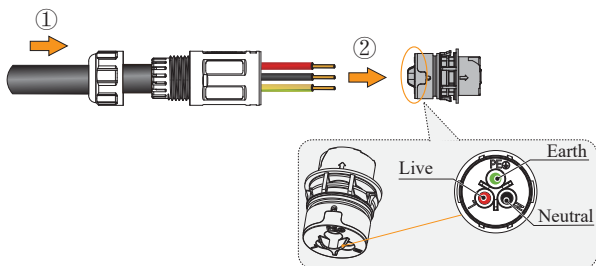

Step 3: Tighten three screws and ensure each screw cap does not exceed the surface.

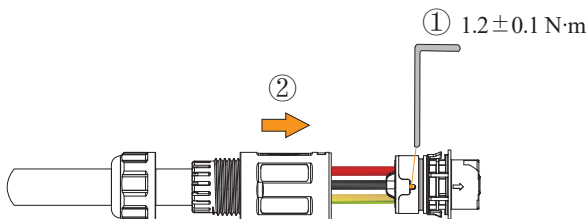

Step 4: Install the connector to the “BACKUP” port.

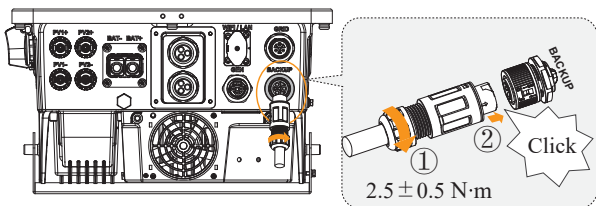

4.3.2 GEN Connection

Before connecting the GEN terminal, ensure that both the AC terminal and the DC terminal are powered OFF and the PV switch is OFF. Otherwise there is a risk of high voltage shock.

Step 1: Select the cable.

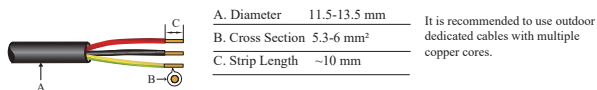

Step 2: Thread the cable and crimp the wire ferrules.

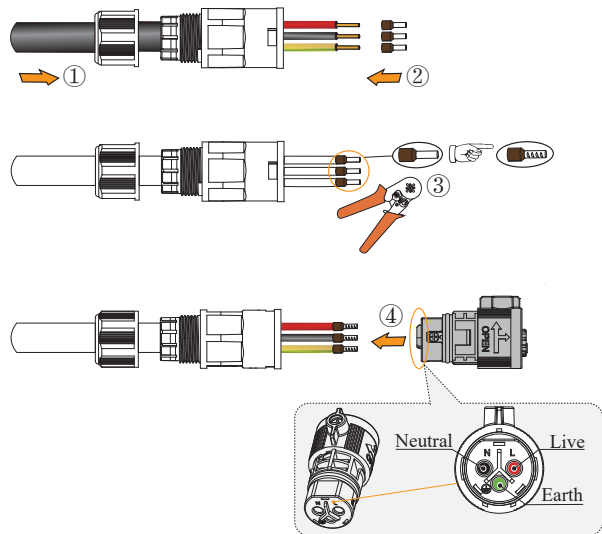

Step 3: Tighten three screws and ensure each screw cap does not exceed the surface.

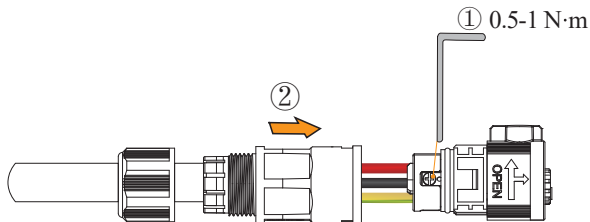

Step 4: Install the connector to the “GEN” port.

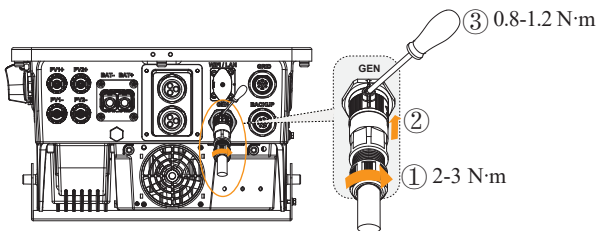

4.4 Battery Connection

Hybrid inverter now only supports the lithium / lead-acid battery. This part in this manual only describe the battery connection on inverter side. If you need more detailed connection information about the battery side, please refer to the manual of the battery you using.

Before connecting to battery, please install a separate DC breaker (150A; not equipped) between inverter and battery. This ensure the inverter can be security disconnected during maintenance.

Step 1: Prepare the proper cable we recommended, and strip an appropriate length of the cable insulation.

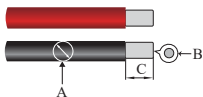

Model	A	B	C
5K/6K	9-10.5 mm	25-26.7 mm ²	~20 mm

Step 2: Thread the wires.

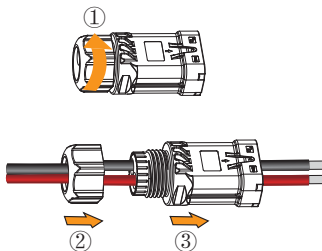

Step 3: Insert the wires into the rubber core according to the line sequence and put the cable in place through the perspective hole.

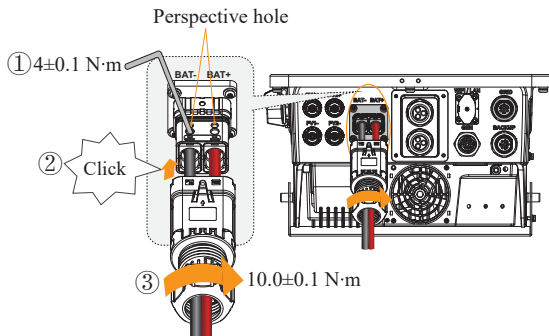

WARNING

- Polarity reverse will damage the inverter!
- Be careful of electric shock and chemical hazards!
- To reduce risk of injury, please use the suitable recommended cable size.

Battery Communication Connection

If the battery type is lithium battery which need communication between the inverter and battery management system(BMS), the connection must be installed.

Please refer to section 4.7.1 for details.

4.5 PV Connection

PV connection please refer to below.

Step 1: Wires making.

NOTE!

PV cable should be dedicated PV cable (suggest using 4 - 6mm² PV1-F cable).

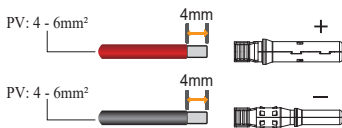

Step 2: Insert the exposed areas of the positive and negative cables into the metal terminals of the positive and negative connectors respectively and crimp them with a crimping tool. Then insert the crimped positive and negative cables into the corresponding positive and negative connectors.

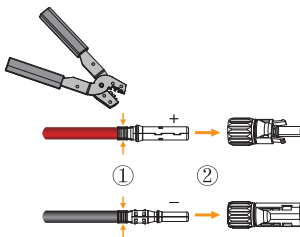

Step 3: Tighten the waterproof nuts on each connector with a tool to avoid loosening.

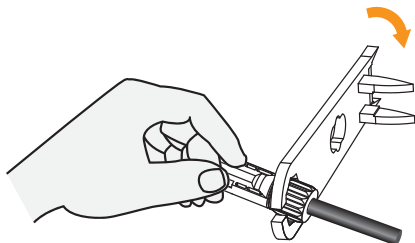

Step 4: Test string voltage and confirm string polarity.

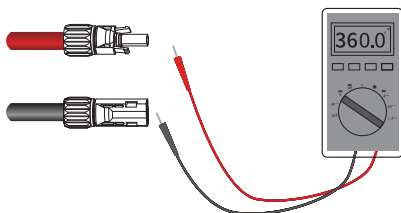

Step 5: Ensure that the PV switch is OFF.

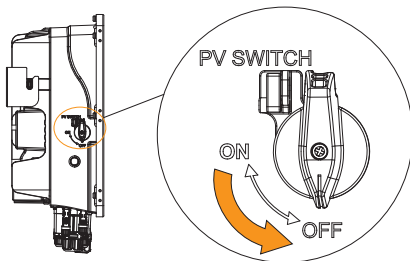

Step 6: Insert the positive and negative connectors into the PV+/PV- ports until a “click” sound is heard.

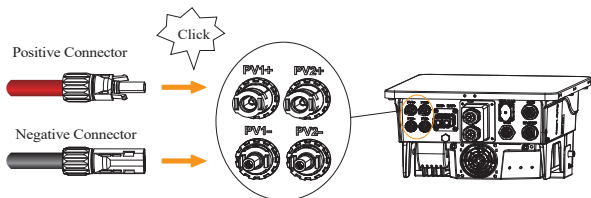

WARNING

- Before connection the PV panels, make sure the plug connector have the correct polarity. Incorrect polarity could permanently damage the inverter.
- PV array shouldn't be connected to the grounding conductor.
- The minimum insulation resistance to ground of the PV panels must exceed 18.33k Ω , there is a risk of shock hazard if the requirement of minimum resistance is not met.

4.6 Communication Interface Connection

There are communication interfaces in the communication port on the bottom of the inverter as show below:

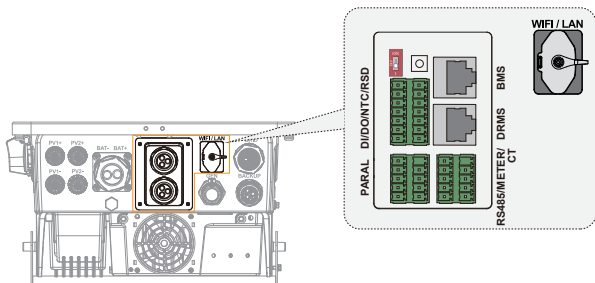

Interface	Descriptions	
BMS	Lithium battery communication interface	
DRMS	Demand response mode for Australia application	
RS485/METER/CT	RS485 communication (monitor/meter) or Grid current sense	
PARAL	10-Pin interface for parallel communication	
	A matched resistance switch for parallel communication	
14-Pin	DI	Dry contact input1/2 control (reserved)
	DO	Dry contact output1/2 control(reserved)
	NTC	Temperature sensor terminal of lead-acid battery
	RSD	RSD control power and remote off
WIFI/LAN	WIFI/LAN	

4.6.1 BMS Connection for Lithium Battery

NOTICE

This manual ONLY illustrates the pinout sequence of BMS at INVERTER SIDE. For details about the pinout sequence at battery side, see the user manual of the battery you use, and the following pinout diagram of battery side is only for illustration.

Standard RJ45 Pinout

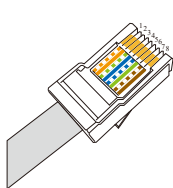

RJ45 Pin Configuration	
Pin	Color
1	White-Orange
2	Orange
3	White-Green
4	Blue
5	White-Blue
6	Green
7	White-Brown
8	Brown

Always face the flat side of the terminal, and count the pin slots from left to right, which correspond to 1 to 8. Read the pin definitions of both the battery and inverter carefully.

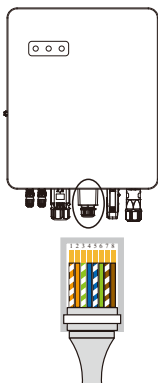

Pin (Inverter)	Function Description
1	RS485_A3 (for BMS)
2	RS485_B3 (for BMS)
3	GND_S
4	CAN_H
5	CAN_L
6	NC
7	CAN_L
8	CAN_H

Example of a battery's pin configuration:

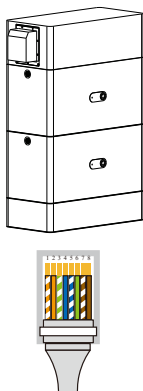

Pin (Inverter)	Function Description
1	NC
2	NC
3	GND_S
4	CAN_H
5	CAN_L
6	GND_S
7	NC
8	NC

CAN BUS connection principle

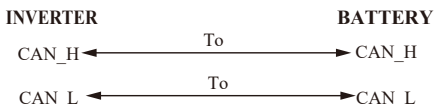

BMS communication cable preparation

1. Prepare RJ45 terminals and strip appropriate length of COM cables.
2. According to pin definitions and cable order, assemble the RJ45 terminals and crimp communication wires. There are two methods to assemble the RJ45 terminals.

Method 1: Use the INVERTER RJ45 pinout as the standard pinout to crimp wires, then the battery side will be a non-standard one (special pinout). Cut off the other no-used wires (1/2/3/6/7/8) for the battery RJ45 terminal.



Method 2: Use the BATTERY RJ45 pinout as the standard pinout to crimp wires, then the inverter side will be a non-standard one (special pinout). Cut off the other no-used wires (1/2/3/6/7/8) for the inverter RJ45 terminal.

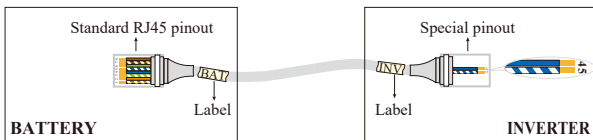

3. Then label the RJ45 terminals (BAT or INV) to avoid confusion.
4. After finishing wire-making, use a multimeter or other specific tool to check if your cable is good, bad, or wired incorrectly.

BMS communication cable connection

Step 1: Unscrew the waterproof cover, then loosen the rubber nut on waterproof cover and finally remove the sealing plugs.

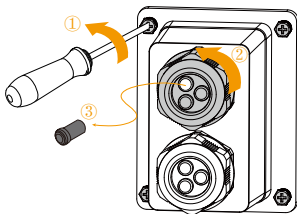

Step 2: Lead the BMS cable through the rubber nut, seal and waterproof cover in turn.

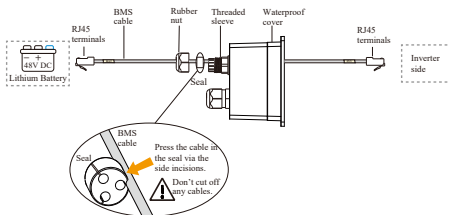

Step 3: Insert the terminal.

1. Insert the terminal into corresponding port.
2. Screw the waterproof cover back to inverter firmly with 4 x M4 screws(1.2N·m).
3. Install the seal into the threaded sleeve, fasten the rubber nut.

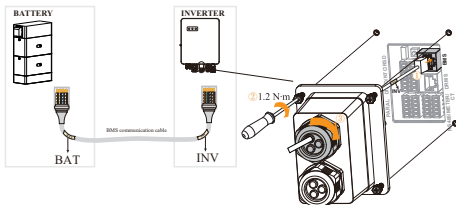

4.6.2 DRMs Connection

DRMs is a shortened form for “inverter demand response modes”.

NOTE!

With DRMs connection, it is necessary to connect APP to inverter and then go to Console > Other Setting page to enable DRM function on APP. Please refer to page 63.

RJ45 Terminal Configuration of DRMs

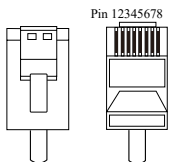

Pin	Function Description	Pin	Function Description
1	DRM1/5	5	REF
2	DRM2/6	6	DRM 0/COM
3	DRM3/7	7	NC
4	DRM4/8	8	NC

DRMS cable connection procedure

Step 1: Unscrew the waterproof cover, then loosen the rubber nut on waterproof cover and finally remove the sealing plugs.

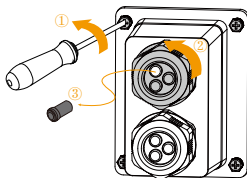

Step 2: Thread the cables and make the terminal.

1. Lead the cable through the rubber nut, seal and waterproof cover in turn.
2. Make the RJ45 terminal according to the above pin definition.

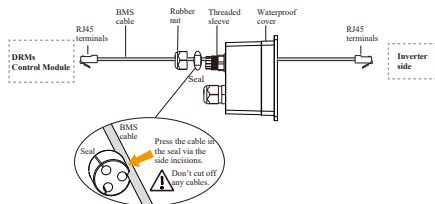

Step 3: Insert the terminal.

1. Insert RJ45 terminal into corresponding port.
2. Screw the waterproof cover back to inverter firmly with 4 x M4 screws(1.2N·m).
3. Install the seal into the threaded sleeve, fasten the rubber nut.

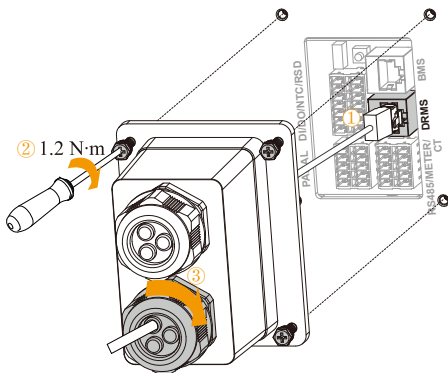

4.6.3 RS485/Meter/CT Connection

RJ45 Terminal Configuration of Meter/CT Communication

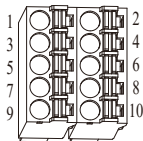

Pin	Function Description	Pin	Function Description
1	RS485_A1 (for Meter)	2	NC
3	RS485_B1 (for Meter)	4	I_CT- (for CT)
5	NC	6	I_CT+ (for CT)
7	RS485_A2 (for Common Use)	8	+3.3V (for CT)
9	RS485_B2 (for Common Use)	10	CT_DET (for CT)

Pin	Distance	CT	Meter	CT+Meter
1	≤ 3m	✓	✓	✓
	3 - 10m	✓	✓	
	> 10m		✓	
2 - 3	≤ 3m	✓		✓
	3 - 10m	✓		
	> 10m			
> 3	≤ 3m			✓
	3 - 10m			
	> 10m			

NOTE!

- CT: 3m cable length (default); 10m cable length (optional). Do not extend the CT cable.

- Meter (optional): wire length up to 100m.

- For CT+Meter connection, it is necessary to additionally purchase suitable CT and meter from customer service according to the specific requirements.

4.6.3.1 RS485 Connection

Pin definition of terminal:

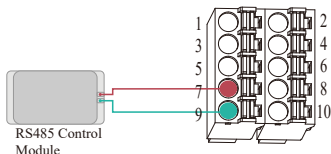

Pin (Terminal)	Function Description
7	RS485_A2
9	RS485_B2

RS485 cable connection procedure

Step 1: Unscrew the waterproof cover, then loosen the rubber nut on waterproof cover and finally remove the sealing plugs.

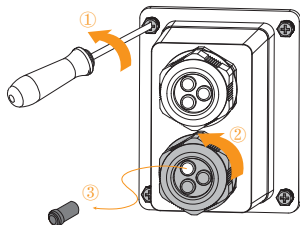

Step 2: Thread the cables and and make the terminal.

1. Lead the cable through the rubber nut, seal and waterproof cover in turn.
2. Make the terminal according to the above pin definition.

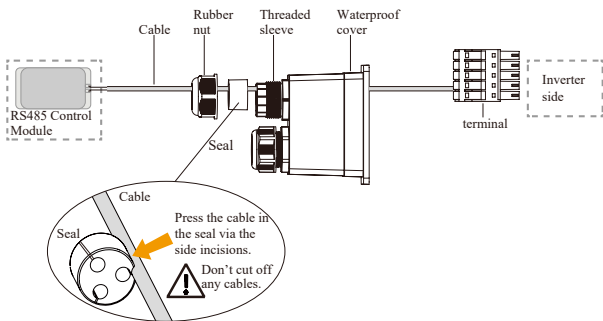

Step 3: Insert the terminal.

1. Insert the terminal into corresponding port.
2. Screw the waterproof cover back to inverter firmly with 4 x M4 screws(1.2N·m).
3. Install the seal into the threaded sleeve, fasten the rubber nut.

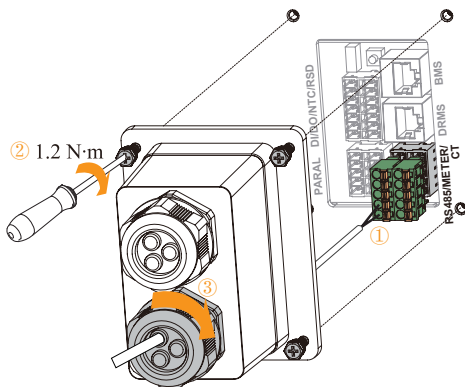

4.6.3.2 CT Connection

There are three ways to sample the grid voltage and current: CT, meter and CT+meter.

There are two connection diagrams of CT power cable, which are shown as below:

- CT at grid side

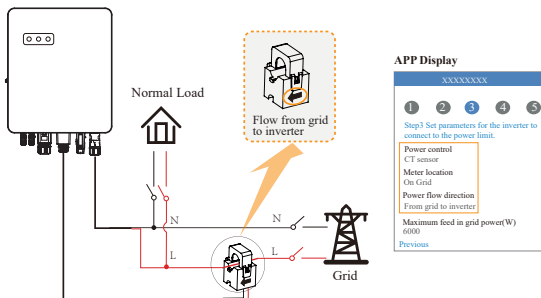

Please pay attention to the direction of current transformer (CT). The arrow on the CT indicates the direction of current flow from grid to inverter.

⚠ NOTICE

The current direction from grid to inverter is defined as positive and current direction from inverter to grid is defined as negative.

- CT at load side

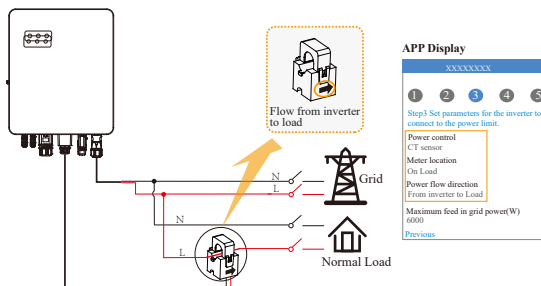

Please pay attention to the direction of current transformer (CT). The arrow on the CT indicates the current flow from inverter to load.

⚠ NOTICE

The current direction from inverter to load is defined as positive and current direction from load to inverter is defined as negative.

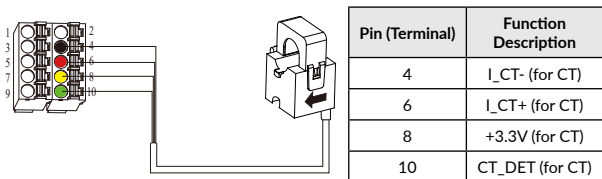

CT cable connection procedure

NOTE!

Ensure that the inverter is completely powered off before connecting the CT cable.

Step 1: Unscrew the waterproof cover, then loosen the rubber nut on waterproof cover and finally remove the sealing plugs.

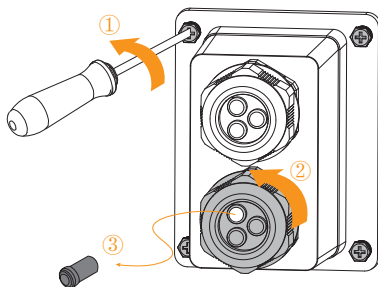

Step 2: Thread the cables and make the terminal.

1. Lead the cable through the rubber nut, seal and waterproof cover in turn.
2. Make the terminal according to the above pin definition.

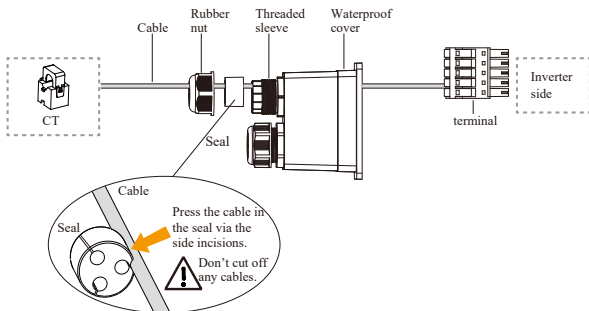

Step 3: Insert the terminal.

1. Insert the terminal into corresponding port.
2. Screw the waterproof cover back to inverter firmly with 4 x M4 screws(1.2N·m).
3. Install the seal into the threaded sleeve, fasten the rubber nut.

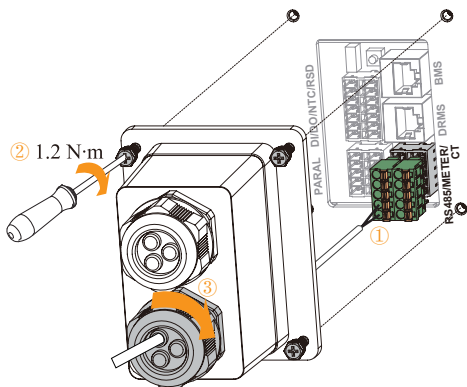

4.6.3.3 Meter Connection

This solution only supports the CHINT-DDSU666 5(80)A meter. There are two connection diagrams of energy meter, which are shown as below:

- Meter at grid side

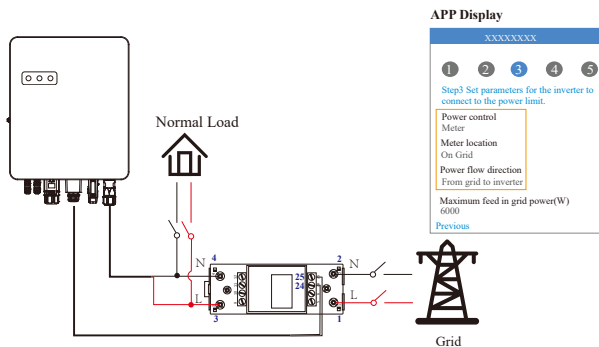

- Meter at grid side

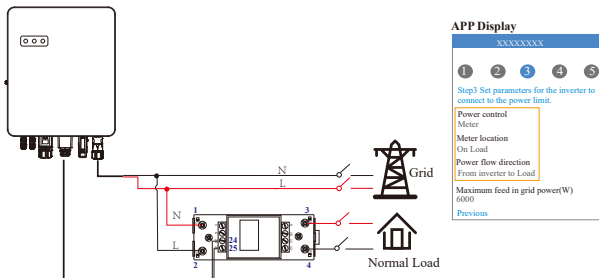

As for the detail application of meter, please refer to the meter instruction manual.

Pin definition of terminal:

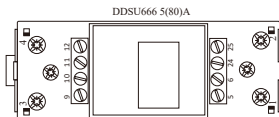
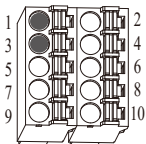

Pin (Terminal)	Function Description
1	RS485_A1 (for Meter)
2	RS485_B1 (for Meter)

Pin (Meter)	Function Description
1	Grid_L
2	Grid_N
3	Hybrid/PV inverter_L
4	Hybrid/PV inverter_N

Meter cable connection procedure

Step1: Unscrew the waterproof cover, then loosen the rubber nut on waterproof cover and finally remove the sealing plugs.

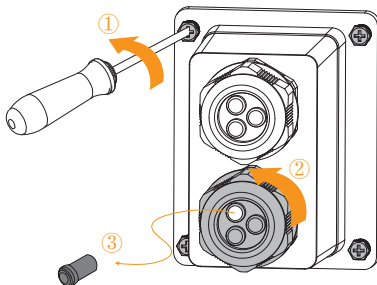

Step2: Thread the cables and make the terminal.

1. Lead the meter communication cable through the rubber nut, seal and waterproof cover in turn.
2. Make the terminal according to the above pin definition.

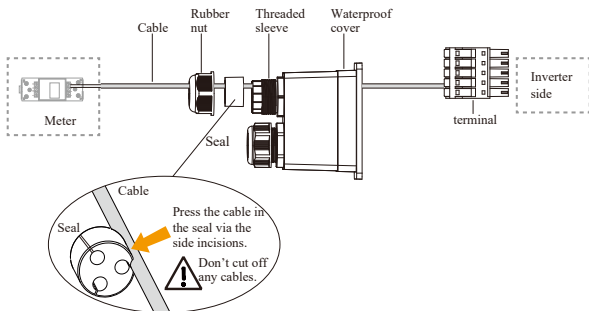

Step3: Insert the terminal.

1. Insert the terminal into corresponding port.
2. Screw the waterproof cover back to inverter firmly with 4 x M4 screws(1.2N·m).
3. Install the seal into the threaded sleeve, fasten the rubber nut.

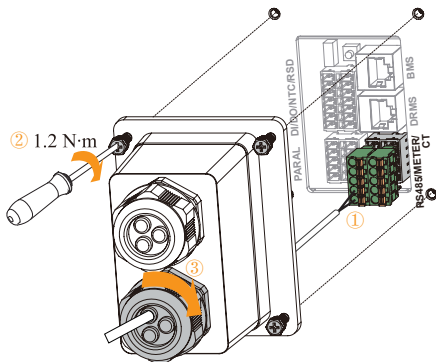

4.6.3.4 CT+Meter Connection

This solution only supports the CHINT-DDSU666 1.5(6)A meter. The CT and meter are optional.

The connection diagram for CT locating at grid side is shown as below:

- CT at grid side

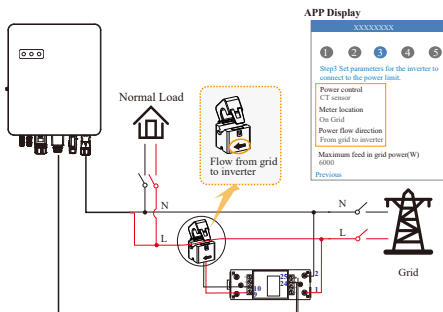

- CT at load side

For CT locating at normal load side, please refer to the charter CT Connection > CT at load side.

As for the detail application of meter, please refer to the meter instruction manual.

Pin definition of terminal:

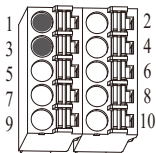

Pin (Terminal)	Function Description
1	RS485_A1 (for Meter)
2	RS485_B1 (for Meter)

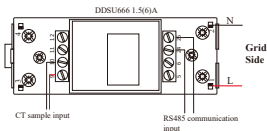

Pin (Meter)	Function Description
1	Grid_L
2	Grid_N
3	Hybrid/PV inverter_L
4	Hybrid/PV inverter_N
24	RS485_A
25	RS485_B

Meter cable connection procedure

Step1: Unscrew the waterproof cover, then loosen the rubber nut on waterproof cover and finally remove the sealing plugs.

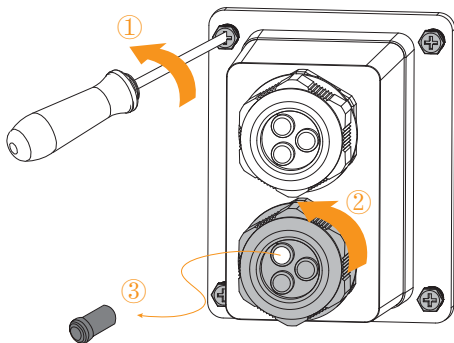

Step2: Thread the cables and make the terminal.

1. Lead the meter communication cable through the rubber nut, seal and waterproof cover in turn.
2. Make the terminal according to the above pin definition.

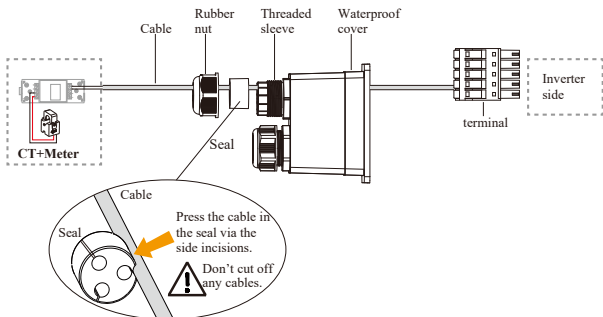

Step3: Insert the terminal.

1. Insert the terminal into corresponding port.
2. Screw the waterproof cover back to inverter firmly with 4 x M4 screws(1.2N·m).
3. Install the seal into the threaded sleeve, fasten the rubber nut.

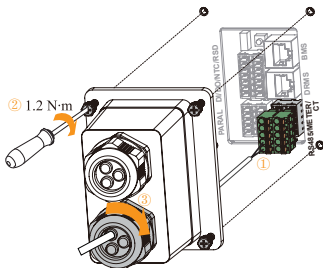

4.6.4 DI/DO/NTC/RSD Connection

Pin definition of terminal

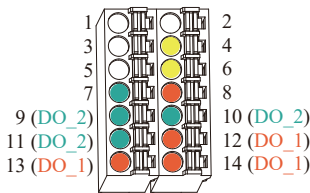

Pin (Terminal)	Function Description	Pin (Terminal)	Function Description
1	+12V	8	DI_1 (Reserve for Data Input1)
2	NC	9	NC2 (Normal Close)
3	RSD/EPO	10	N2 (Common Pole)
4	GND_S (for NTC)	11	NO2 (Normal Open)
5	GND_S (for RSD/EPO/ +12V/Dry Contact)	12	NC1 (Normal Close)
6	TH_NTC	13	N1 (Generator Control)
7	DI_2 (Reserve for Data Input2)	14	NO1 (Generator Control, Normal Open)

Cables connection procedure connection

Step1: Unscrew the waterproof cover, then loosen the rubber nut on waterproof cover and finally remove the sealing plugs.

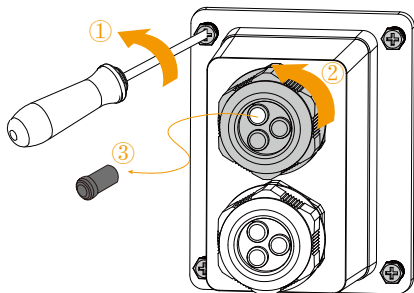

Step2: Thread the cables and make the terminal.

1. Lead the cable through the rubber nut, seal and waterproof cover in turn.
2. Make the terminal according to above function description of each Pin definition for the auxiliary port you want to use.

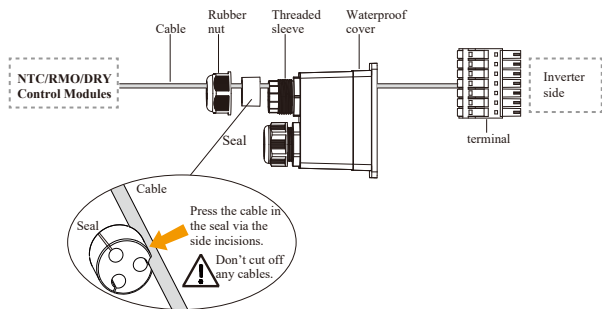

Step3: Insert the terminal.

1. Insert the terminal into corresponding port.
2. Screw the waterproof cover back to inverter firmly with 4 x M4 screws(1.2N·m).
3. Install the seal into the threaded sleeve, fasten the rubber nut.

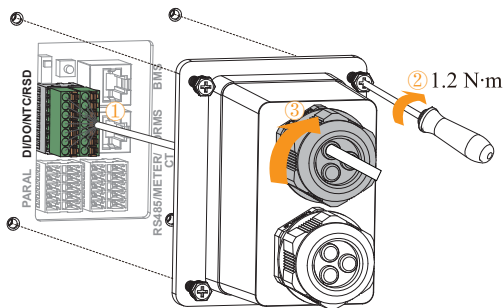

Step4: Connect the other end of the NTC cable. (Only for NTC)

NOTE!

NTC connection for lead-acid battery

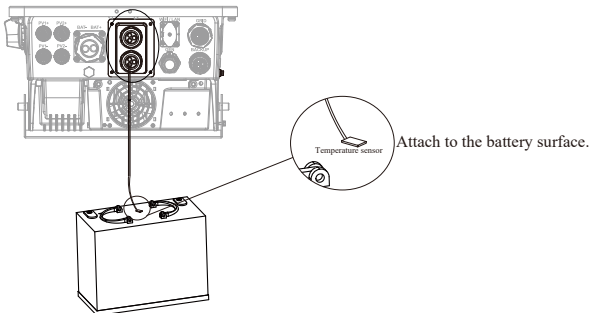

4.6.5 Parallel Communication Connection

Pin definition of terminal

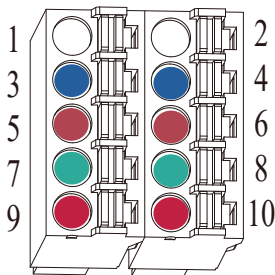

Pin (Terminal)	Function Description
1	NC
2	NC
3	GND_S
4	GND_S
5	PARA_SYNC
6	PARA_SYNC
7	CAN_L
8	CAN_L
9	CAN_H
10	CAN_H

Parallel cable connection procedure connection

Step 1: Unscrew the waterproof cover, then loosen the rubber nut on waterproof cover and finally remove the sealing plugs.

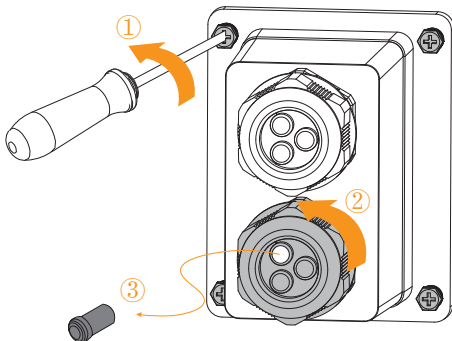

Step 2: Thread the cables and make the terminal.

1. Lead the parallel communication cable through the rubber nut, seal and waterproof cover in turn.
2. Make the terminal according to the above pin definition.

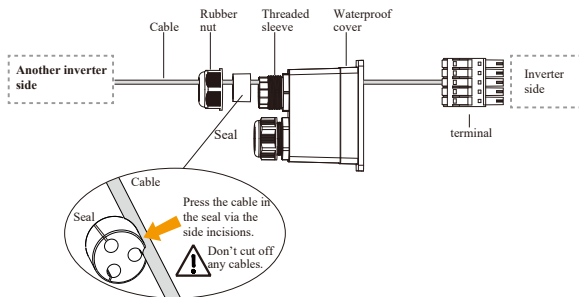

Step 3: Insert the terminal.

1. Insert the terminal into corresponding port.
2. Screw the waterproof cover back to inverter firmly with 4 x M4 screws (1.2N·m).
3. Install the seal into the threaded sleeve, fasten the rubber nut.

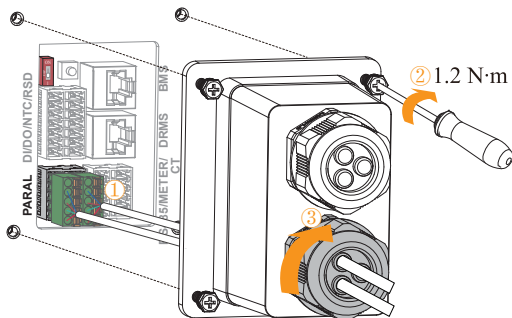

Parallel communication cables connection between different inverters

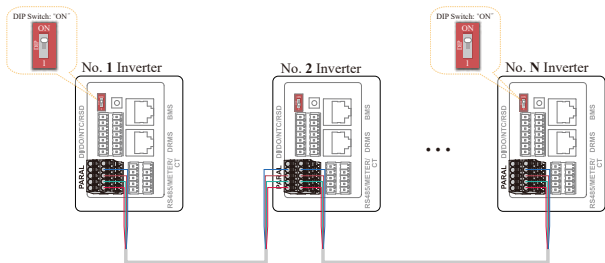

It is necessary to turn the matched resistance switch of No. 1 inverter and No. N inverter to “ON” in parallel connection mode.

4.6.6 DRMs Connection

DRMs is a shortened form for “inverter demand response modes”.

NOTE!

With DRMs connection, it is necessary to connect the app to inverter and then go to **Console > Other Setting** page to enable **DRM** function on the app.

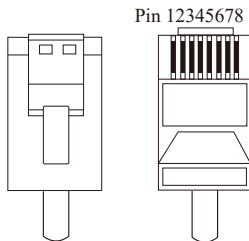

Pin (Terminal)	Function Description
1	DRM 1/5
2	DRM 2/6
3	DRM 3/7
4	DRM 4/8
5	REF
6	DRM 0/COM
7	NC
8	NC

DRMS cable connection procedure

Step 1: Unscrew the waterproof cover, then loosen the rubber nut on waterproof cover and finally remove the sealing plugs.

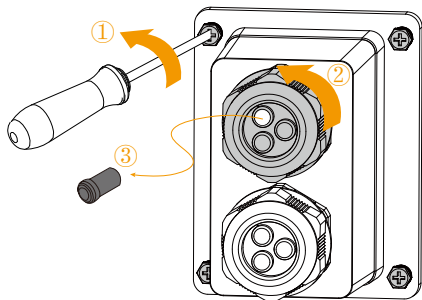

Step 2: Thread the cables and make the terminal.

1. Lead the cable through the rubber nut, seal and waterproof cover in turn.
2. Make the RJ45 terminal according to the above pin definition.

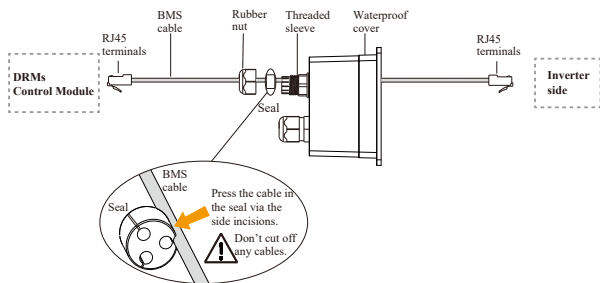

Step 3: Insert the terminal.

1. Insert RJ45 terminal into corresponding port.
2. Screw the waterproof cover back to inverter firmly with 4 x M4 screws(1.2N·m).
3. Install the seal into the threaded sleeve, fasten the rubber nut.

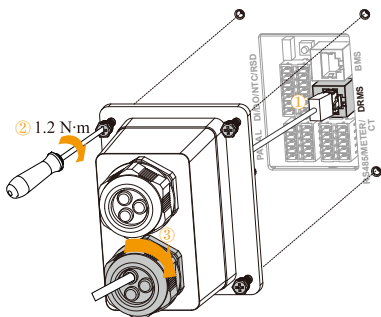

4.6.7 WIFI/LAN Module Connection

For details, please refer to the corresponding Module Installation Guide in the packing.

The module installation procedure:

Step 1: Move the cover.

WIFI / LAN

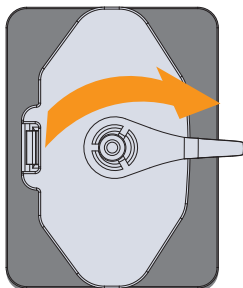

Step 1: Insert WIFI/LAN module into WIFI/LAN port, and ensure that it does not fall off.

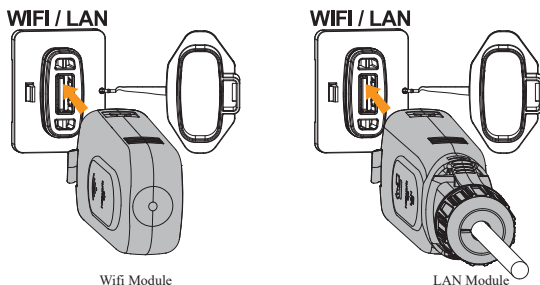

5 System Operation

5.1 Inverter Working Mode

The inverter supports several different working modes.

5.1.1 Self consumption mode

Go to the “Hybrid work mode” menu, and select the “Self consumption mode” working mode. Under Self consumption mode, the priority of PV energy will be Load > Battery > Grid, that means the energy produced by PV gives priority to local loads, excess energy is used for charging the battery, and the remaining energy is fed into the grid.

This is the default mode to increase self-consumption rate. There are several situations of Self consumption mode working mode based on PV energy.

a) Wealthy PV Energy

When PV energy is wealthy, the PV energy will first consumed by loads, the excess energy will be used to charge the battery then the remaining energy will be fed into the grid.

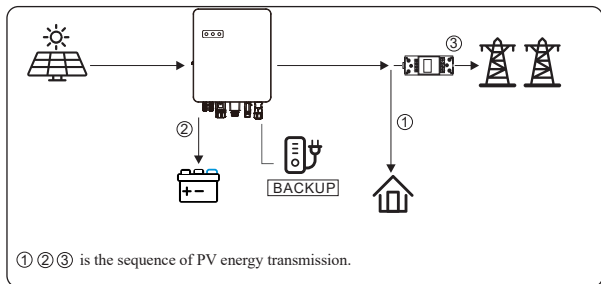

b) Limited PV power

When the PV energy is not enough to cover all the loads, all the PV energy will be used for load, and the insufficient part will be supported by battery. Then still insufficient parts will be supported by grid.

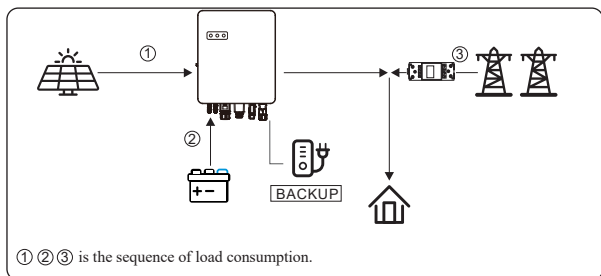

c) No PV Input

The inverter will first discharge the battery energy for home load consuming when no PV input (such as in the evening or some cloudy or rainy days). If the demand is not met then will consume the grid energy.

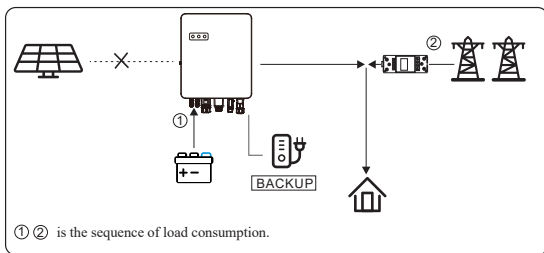

5.1.2 Feed-in Priority Mode

Go to the “Hybrid work mode” menu, and select the “Feed-in priority mode” working mode. Under this mode, the priority of PV energy will be Load > Grid > Battery, that means the energy produced by PV gives priority to local loads, excess energy is fed into the grid, and the remaining energy is used for charging the battery.

a) Wealthy PV Energy

When PV energy is wealthy, the PV energy will be first consumed by loads, if there is excess PV power, then the excessive power will be fed into grid. If there is still PV energy rested after load consuming and grid feeding, then the rested PV power will be used to charge the battery.

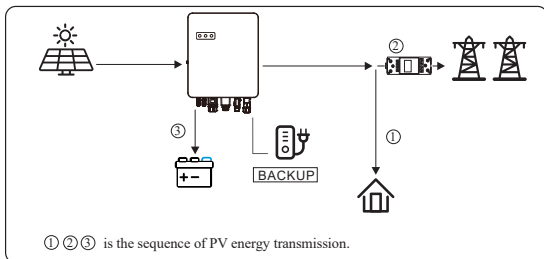

b) Limited PV Energy

When PV energy is limited and can not meet the feed-in grid power, the battery will discharge to meet it.

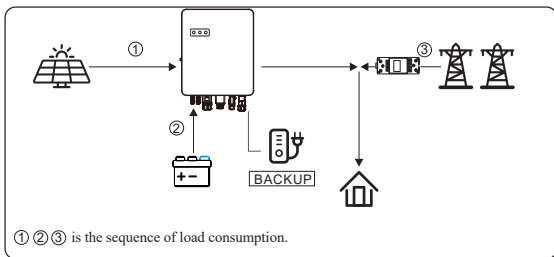

c) No PV Input

The inverter will first discharge the battery energy for home load consuming when no PV input (such as in the evening or some cloudy or rainy days). If the demand is not met then will consume the grid energy.

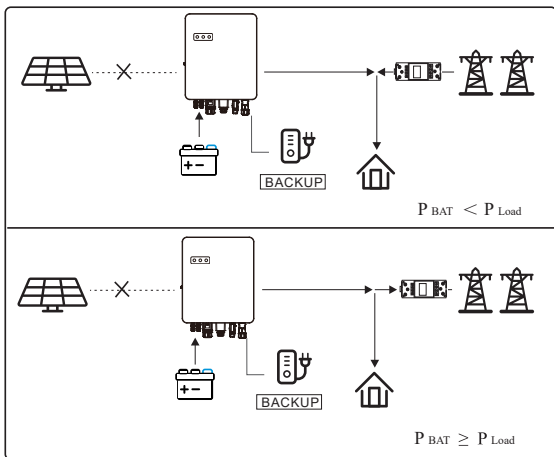

5.1.3 Forced Charge/Discharge Function

According to the demands of application, the user can set the inverter to work on forced charge/discharge the battery in any working mode. Please go to **Console > Hybrid Setting > Work mode** to enable **Time-based Control** on APP. There are three time periods in which you can set this function. Outside of the set periods, the inverter returns to its original working mode. The forced charge/discharge function has the highest priority. For setting details, refer to Work mode in Console section. The relationship between the forced charge/discharge function and working mode shown as below.

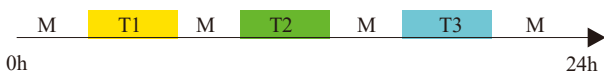

M : Self Use Mode/Feed-in Priority Mode/Back-up Mode.

T1: Time period 1 for forced charge/discharge parameter setting.

T2: Time period 2 for forced charge/discharge parameter setting.

T3: Time period 3 for forced charge/discharge parameter setting.

T1, T2, and T3 priority to M.

5.1.4 Back-up Mode

Go to the “Hybrid work mode” menu, and select the “Back-up Mode” working mode. Under this mode, the priority of PV energy will be Battery > Load > Grid.

This mode aims at charging the battery quickly, and at the same time, you can choose whether to allow AC to charge the battery.

Forbid AC charging

In this mode, the battery can be charged only with PV power, and the charging power varies with PV power.

a) Wealthy PV power

When PV energy is wealthy, PV charges the battery first, then meets the load, and the rest is fed into the grid.

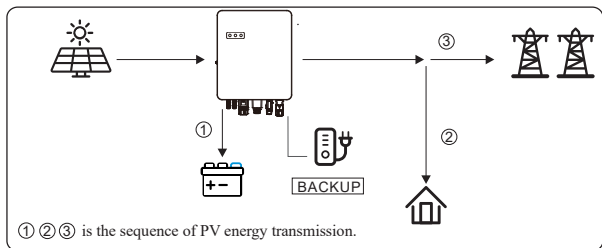

b) Limited PV power

When PV energy is limited, PV gives priority to charging the battery, and the grid directly meet the load demand.

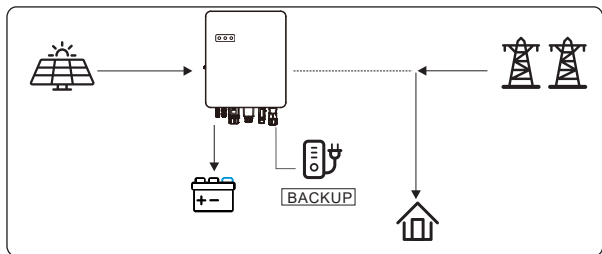

Allow AC charging

In this situation, the battery can be charged both with PV and AC.

a) Wealthy PV power

When PV energy is wealthy, PV charges the battery first, then meets the load, and the rest is fed into the grid.

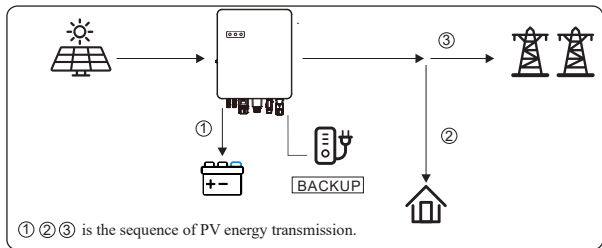

b) Limited PV power

When the PV energy is not enough to charge the battery, the grid energy will charge the battery as supplement. Meanwhile, the grid energy is consumed by loads.

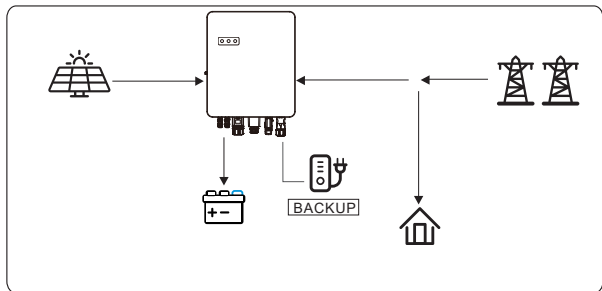

5.1.5 Off Grid Mode

When the power grid is cut off, the system automatically switches to Off Grid mode. Under off-grid mode, only critical loads are supplied to ensure that important loads continue to work without power failure.

Under this mode, the inverter can't work without the battery.

a) Wealthy PV power

When PV energy is wealthy, the PV power will be first consumed by critical load, charging batteries and, conditioned, by the smart load (only if PV power is above 500W and the Battery charge level is more than 90%).

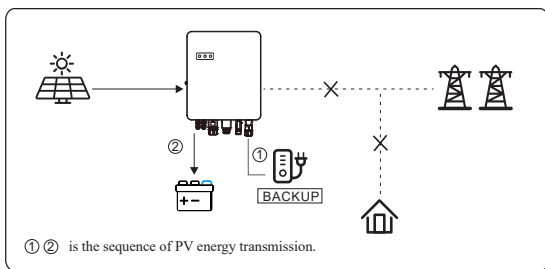

b) Limited PV power

When PV energy is limited, Backup loads are first powered by PV and then supplemented by battery.

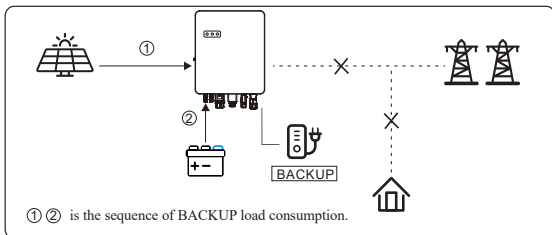



NOTICE

-Under this mode, please complete the output voltage and frequency settings.

-It is better to choose the battery capacity larger than 100Ah to ensure Backup function work normally.

-If Backup output loads are inductive or capacitive loads, to make sure the stability and reliability of system, it is recommended to configure the power of these loads to be within 50% Backup output power range.

5.2 Startup/Shutdown the System

No.	Items
1	The inverter is firmly installed.
2	There is enough heat dissipation space, no external objects or parts left on the inverter
3	It is convenient for operation and maintenance.
4	The wiring of the system is correct and firm.
5	Check whether the DC and AC connections are correct with a multimeter, and ensure there is no short circuit, break, or wrong connection.
6	Check whether the waterproof nuts of each part are tightened.
7	The vacant ports have been sealed. All gaps at the cable inlet and outlet holes have been plugged with fireproof/waterproof materials, such as fireproof mud.
8	All safety labels and warning labels on the inverter are complete and without occlusion or alteration.
9	Confirm the parameters and configurations conform to relevant requirements. <ul style="list-style-type: none">● AC Frequency: 50/60 Hz● PV Voltage: 70 V DC to 550 V DC● Battery Voltage: 40 V DC to 65 V DC● Grid AC Voltage: 176 V AC to 264 V AC

5.2.1 Startup the System

Make sure all the above aspects are right, and then follow the procedure to start up the inverter:

- 1) Power on PV.
- 2) Power on the Battery.
- 3) Power on the AC.
- 4) Power on the BACKUP.
- 5) Turn on the inverter. For the first startup, refer to the Startup Guide to complete Quick Settings on the LCD or Quick Setup on the app and tap the Power-on icon to turn on the inverter. For the non-first-time startup, press and hold the ON/OFF button on the side of the inverter for five seconds to turn it on.

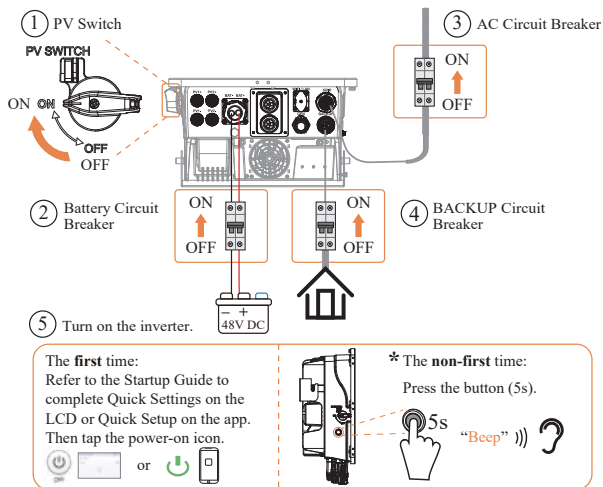

5.2.2 Shutdown the System

According to actual situation, if there is a must to shut down the running system, please follow the procedure below:

- 1) Turn off the inverter. Tap the Power-off icon on the LCD home screen or app Quick Setup page to turn off the inverter. Or you can press and hold the ON/OFF button on the side of the inverter for five seconds to turn it off.
- 2) Power off the BACKUP.
- 3) Power off the AC.
- 4) Power off the Battery.
- 5) Power off the PV.
- 6) If you need to disconnect the inverter cables, please wait at least 10 minutes before touching these parts of inverter.



DANGER

After the inverter is powered off, the remaining electricity and heat may still cause electric shock and body burns. If need to disconnect the inverter cables, please wait at least 10 minutes before touching these parts of inverter.

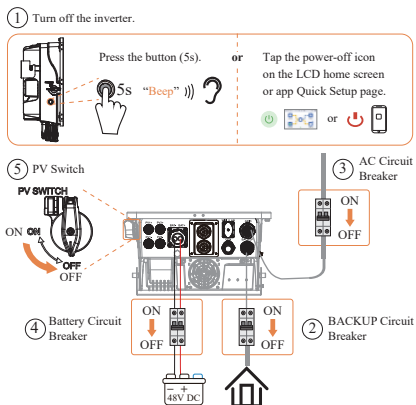

It is necessary to make a complete commissioning of the inverter system. This will essentially protect the system from fire, electric shock or other damages or injuries.

6.1 Inspection

Before commissioning, the operator or installer (qualified personnel) must inspect the system carefully and make sure:

- 1) The system is firmly installed correctly following the contents and notifications of this manual, and there are enough spaces for operation, maintenance and ventilation.
- 2) All the terminals and cables are in good status without any damages.
- 3) No objects are left in/on the inverter or within the required clearance.
- 4) The PV, battery pack is working normally, and grid is normal.

6.2 Commissioning Procedure

When all items have been checked and the system is ready for use, start the commissioning procedure.

- 1) Power on the system by referring to the Startup section 5.2.1.
- 2) Set the parameters on the App according to user's requirement.
- 3) Finish commissioning.

7 User Interface

7.1 LED

Button holding time	Function
1s	Clear the overload alarm
5s	ON/OFF inverter

7.2 LED Introduction

This section describes the LED panel. LED indicators include a green LED, blue and red LED indicator.

It includes the explanation of indicator states and summary of indicator states under the running state of the machine.

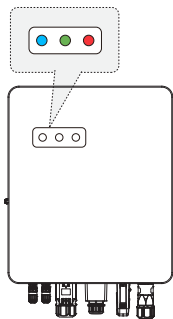

Inverter status	Green LED Color/status	Blue LED color/status	Red LED color/status
Standby	Green/2s on and 2s off	Light off	Light off
on-grid	Green/light on continuous	Light off	Light off
off-grid	Light off	Blue/light on continuous	Light off
fault	Light off	Light off	Red / light on continuous
		Light alternately (1 color/0.25s)	Burning code

**CAUTION**

Before maintaining and commissioning inverter and its peripheral distribution unit, switch off all the charged terminals of the inverter and wait at least 10 minutes after the inverter is powered off.

8.1 Routine Maintenance

Items	Check Content	Maintain Content	Maintenance Interval
Inverter output status	Statistically maintain the status of electrical yield, and remotely monitor its abnormal status.	N/A	Weekly
Inverter cleaning	Check periodically that the heat sink is free from dust and blockage.	Clean periodically the heat sink.	Yearly
Inverter running status	Check that the inverter is not damaged or deformed. Check for normal sound emitted during inverter operation. Check and ensure that all inverter communications is running well.	If there is any abnormal phenomenon, replace the relevant parts.	Monthly
Inverter electrical connections	Check that all AC, DC and communication cables are securely connected; Check that PGND cables are securely connected; Check that all cables are intact and free from aging.	If there is any abnormal phenomenon replace the cable or re-connect it.	Semiannually

8.2 Inverter Troubleshooting

When the inverter has an exception, its basic common warning and exception handling methods are shown below.

Code	Alarm Information	Suggestions
A0	Grid over voltage	1. If the alarm occurs occasionally, possibly the power grid voltage is abnormal for a short time, and no action is required. 2. If the alarm occurs repeatedly, contact the local power
A1	Grid under voltage	station. After receiving approval of the local power bureau, revise the electrical protection parameters settings on the inverter through the App. 3. If the alarm persists for along time, check whether the AC circuit breaker /AC terminals is disconnected or not, or if the grid has a power outage.
A3	Grid over frequency	
A4	Grid under frequency	
A2	Grid absent	Wait till power is restored.
B0	PV over voltage	Check whether the maximum voltage of a single string of input PV modules is greater than the allowable voltage. If the maximum voltage is higher than the standard voltage, modify the number of pv module connection strings.
B1	PV insulation abnormal	1. Check the insulation resistance against the ground for the PV strings. If a short circuit has occurred, rectify the fault. 2. If the insulation resistance against the ground is less than the default value in a rainy environment, set insulation resistance protection on the App.

B2	Leakage current abnormal	<p>1. If the alarm occurs occasionally, the inverter can be automatically recovered to the normal operating status after the fault is rectified.</p> <p>2. If the alarm occurs repeatedly, contact your dealer for technical support.</p>
B4	PV under voltage	<p>1. If the alarm occurs occasionally, possibly the external circuits are abnormal accidentally. The inverter automatically recovers to the normal operating status after the fault is rectified.</p> <p>2. If the alarm occurs repeatedly or last a long time, check whether the insulation resistance against the ground of PV strings is too low.</p>
B7	PV string reverse	Check and modify the positive and negative polarity of the input of the circuit string.
C0	Internal power supply abnormal	<p>1. If the alarm occurs occasionally, the inverter can be automatically restored, no action required.</p> <p>2. If the alarm occurs repeatedly, pls. contact the customer service center.</p>
C2	Inverter over dc-bias current	<p>1. If the alarm occurs occasionally, possibly the power grid voltage is abnormal for a short time, and no action is required.</p> <p>2. If the alarm occurs repeatedly, and the inverter fails to generate power, contact the customer service center.</p>

C3	Inverter relay abnormal	<p>1. If the alarm occurs occasionally, possibly the power grid voltage is abnormal for a short time, and no action is required.</p> <p>2. If the alarm occurs repeatedly, pls. refer to the suggestions or measures of Grid over voltage and the inverter fails to generate power, contact the customer service center. If there is no abnormality on the grid side, the machine fault can be determined. And pls. contact the customer service center.</p>
CN	Remote off	<p>1. Local manual shutdown is performed in APP.</p> <p>2. The monitor executed the remote shutdown instruction.</p> <p>3. Remove the communication module and confirm whether the alarm disappears. If it does, replace the communication module. Otherwise, please contact the customer service center.</p>
C5	Inverter over temperature	<p>1. If the alarm occurs occasionally, the inverter can be automatically restored, no action required.</p> <p>2. If the alarm occurs repeatedly, pls. check the installation site for direct sunlight, good ventilation, and high ambient temperature (Such as installed on the parapet). If the ambient temperature is lower than 45 ° C and the heat dissipation is good, contact the customer service center.</p>

C6	GFCI abnormal	<p>1. If the alarm occurs occasionally, it could have been an occasional exception to the external wiring, the inverter can be automatically recovered, no action required.</p> <p>2. If it occurs repeatedly or cannot be recovered for a long time, pls. contact customer service to report repair.</p>
C8	Fan abnormal	<p>1. If the alarm occurs occasionally, pls. restart the inverter.</p> <p>2. If it occurs repeatedly or cannot be recovered for a long time, check whether the external fan is blocked by foreign objects. Otherwise, contact customer service.</p>
C9	DC link unbalance or under voltage	Batteries exceeded their current discharge limit.
CA	DC link over voltage	<p>1. If the alarm occurs occasionally, the inverter can be automatically recovered and no action is required.</p> <p>2. If the alarm occurs repeatedly, the inverter cannot work properly. Pls. contact the customer service center.</p>
CB	Internal communication error	<p>1. If the alarm occurs occasionally, the inverter can be automatically recovered and no action is required.</p> <p>2. If the alarm occurs repeatedly, the inverter cannot work properly. Pls. contact the customer service center</p>
CC	Software incompatibility	<p>1. If the alarm occurs occasionally, the inverter can be automatically recovered and no action is required.</p> <p>2. If the alarm occurs repeatedly, the inverter cannot work properly. Pls. contact the customer service center.</p>
CD	Internal storage error	<p>1. If the alarm occurs occasionally, the inverter can be automatically recovered and no action is required.</p> <p>2. If the alarm occurs repeatedly, the inverter cannot work properly. Pls. contact the customer service center.</p>

CE	Data inconsistency	<ol style="list-style-type: none"> 1. If the alarm occurs occasionally, the inverter can be automatically recovered and no action is required. 2. If the alarm occurs repeatedly, the inverter cannot work properly. Pls. contact the customer service center
CF	Inverter abnormal	<ol style="list-style-type: none"> 1. If the alarm occurs occasionally, the inverter can be automatically recovered and no action is required. 2. If the alarm occurs repeatedly, the inverter cannot work properly. Pls. contact the customer service center.
CG	Boost abnormal	<ol style="list-style-type: none"> 1. If the alarm occurs occasionally, the inverter can be automatically recovered and no action is required. 2. If the alarm occurs repeatedly, the inverter cannot work properly. Pls. contact the customer service center.
CJ	Meter lost	<ol style="list-style-type: none"> 1. Check the meter parameter Settings 2. Local APP checks that the communication address of the inverter is consistent with that of the electricity meter 3. The communication line is connected incorrectly or in bad contact 4. Electricity meter failure. 5. Exclude the above, if the alarm continues to occur, please contact the customer service center.
P1	Parallel ID warning	It is Parallel ID Alarm. Pls. check the parallel communication cable, and check whether any inverter joins or exits online. All inverters are powered off completely, check the line, and then power on the inverters again to ensure that the alarm is cleared.
P2	Parallel SYN signal warning	Parallel synchronization signal is abnormal. Check whether the parallel communication cable is properly connected.

P3	Parallel BAT abnormal	The parallel battery is abnormal. Whether the battery of the inverter is reported low voltage or the battery is not connected.
P4	Parallel GRID abnormal	The parallel grid is abnormal. Whether the grid of the inverter is abnormal.
P5	Phase Sequence abnormal	Ensure that the phase sequence of power grid is consistent with that of L1/L2/L3 on APP. To clear phase sequence abnormal alarm: Option 1: Power off all inverters, correct the phase sequence of each inverter and then restart the inverters. Option 2: Under inverter standby mode, correct the phase sequence of each inverter on APP, power off all inverters and then restart the inverters. If the alarm continues, please contact the customer service center
D2	Battery over voltage	<ol style="list-style-type: none"> 1. If the alarm occurs occasionally, the inverter can be automatically recovered and no action is required. 2. Check that the battery overvoltage protection value is improperly set. 3. The battery is abnormal. 4. If exclude the above, the alarm continues to occur, please contact the customer service center.
D3	Battery under voltage	<ol style="list-style-type: none"> 1. If the alarm occurs occasionally, the inverter can be automatically recovered and no action is required. 2. Check the communication line connection between BMS and inverter (lithium battery). 3. The battery is empty or the battery voltage is lower than the charge level cutoff voltage. 4. The battery undervoltage protection value is improperly set. 5. The battery is abnormal. 6. If exclude the above, the alarm continues to occur, please contact the customer service center.

D4	Battery discharger over current	<ol style="list-style-type: none"> 1. Check whether the battery parameters are correctly set. 2. Battery undervoltage. 3. Check whether a separate battery is loaded and the discharge current exceeds the battery specifications. 4. The battery is abnormal. 5. If exclude the above, the alarm continues to occur, please contact the customer service center.
D5	Battery over temperature	<ol style="list-style-type: none"> 1. If the alarm occurs repeatedly, please check whether the installation site is in direct sunlight and whether the ambient temperature is too high (such as in a closed room). 2. If the battery is abnormal, replace it with a new one. 3. If exclude the above, the alarm continues to occur, please contact the customer service center.
D6	Battery under temperature	
D7	Backup output voltage abnormal	<ol style="list-style-type: none"> 1. Check whether the AC OUTPUT voltage and frequency Settings are within the specified range. 2. Check whether the AC OUTPUT circuit is overloaded. 3. When not connected to the power grid, check whether AC OUTPUT voltage is normal. 4. If exclude the above, the alarm continues to occur, please contact the customer service center.
D8	Communication error (Inverter-BMS)	<ol style="list-style-type: none"> 1. Check whether the battery is disconnected. 2. Check whether the battery is well connected with the inverter. 3. Confirm that the battery is compatible with the inverter. It is recommended to use CAN communication. 4. Check whether the communication cable or port between the battery and the inverter is faulty. 5. If exclude the above, the alarm continues to occur, please contact the customer service center.

D9	Internal communication loss(E-M)	<ol style="list-style-type: none"> 1. Check whether the communication cables between Backup, electricity meter and inverter are well connected and whether the wiring is correct. 2. Check whether the communication distance is within the specification range 3. Disconnect the external communication and restart the electricity meter and inverter.
DA	Internal communication loss(M-D)	<ol style="list-style-type: none"> 4. If exclude the above, the alarm continues to occur, please contact the customer service center.
CU	DC-DC abnormal	<ol style="list-style-type: none"> 1. If the alarm occurs occasionally, the inverter can be automatically recovered and no action is required. 2. If the alarm occurs repeatedly, please check: <ol style="list-style-type: none"> 1) Check whether the MC4 terminal on the PV side is securely connected. 2) Check whether the voltage at the PV side is open circuit, ground to ground, etc. <p>If exclude the above, the alarm continues to occur, please contact the customer service center</p>
CP	AC output over DC bias voltage	<ol style="list-style-type: none"> 1. If the alarm occurs occasionally, the inverter can be automatically recovered and no action is required. 2. If the alarm occurs repeatedly, the inverter cannot work properly. Pls. contact the customer service center

DB	AC output short circuit	<ol style="list-style-type: none"> 1. Check whether the live line and neutral line of AC OUTPUT are short-circuited. 2. If it is confirmed that the output is not short-circuited or an alarm, please contact customer service to report for repair. (After the troubleshooting of alarm problems, AC OUTPUT breaker needs to be manually turned on during normal use.)
DC	AC output over load	<ol style="list-style-type: none"> 1. Disconnect the AC OUTPUT breaker and check whether the alarm is cleared. 2. If the load is disconnected and the alarm is generated, please contact the customer service. (After the alarm is cleared, the AC OUT breaker needs to be manually turned on for normal use.)
DO	Meter 2 lost or device communication loss	<ol style="list-style-type: none"> 1. Check the meter parameter Settings 2. Local APP checks that the communication address of the inverter is consistent with that of the electricity meter 3. The communication line is connected incorrectly or in bad contact. 4. Electricity meter failure. 5. Exclude the above, if the alarm continues to occur, please contact the customer service center.

8.3 Removing the Inverter



WARNING

Before removing DC input connector, double check DC input switch is turned to OFF to avoid inverter damage and personal injury

Perform the following procedures to remove the inverter:

Step 1. Disconnect all cables from the inverter, including communications cables, DC input power cables, AC output power cables, and PGND cable, as shown below.

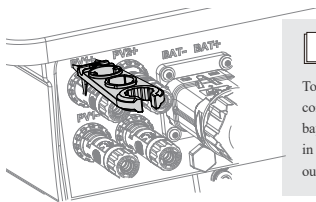

PV Connectors Removing Detail



NOTA

To remove the PV/Grid/BACKUP connectors, insert the removal tool into the bayonet according to the position indicated in the drawing, press inward, and then take out the connector outward.

Step 2. Remove the inverter from the mounting bracket.

Step 3. Remove the mounting bracket.



Disposal of Old Electrical & Electronic Equipment

(Applicable in the European Union and other European countries with separate collection systems)

This symbol on the product or on its packaging indicates that this product shall not be treated as household waste.

Instead it shall be handed over to the applicable collection point for the recycling of electrical and electronic equipment.

By ensuring this product is disposed of correctly, you will help prevent potential negative consequences for the environment and human health, which could otherwise be caused by inappropriate waste handling of this product.

The recycling of materials will help to conserve natural resources.