



Powerhill LV5K-100-B - PDU  
Powerhill LV5K-100-B - Battery Module **User Manual**

---

ESPD05110005PDA01B  
ESWMI51H5110PDA01B

Manual de utilizare



335.42.25.0

Before using this product, carefully read all product documentation and retain it for future reference.

## Contents

<b>Forward</b> .....	<b>1</b>
<b>Package Contents</b> .....	<b>1</b>
<b>1. Safety Information</b> .....	<b>3</b>
1.1 General Safety .....	3
1.2 Personal Safety.....	4
1.3 Electrical Safety.....	4
1.4 Environment Safety .....	5
1.5 Transportation Safety.....	5
<b>2. Product Information</b> .....	<b>7</b>
2.1 Battery Overview .....	7
2.2 Battery Module.....	7
2.3 Port definitions.....	8
2.3.1 Connection Area.....	8
2.3.2 ON/OFF.....	8
2.3.3 Link Communication Port.....	9
2.3.4 Indicator Definition .....	10
2.4 Installation .....	10
<b>3. Maintenance</b> .....	<b>18</b>
<b>Prefata</b> .....	<b>20</b>
Continut Cutie .....	20
<b>1. Informatii de siguranta</b> .....	<b>22</b>
1.1 Conditii de siguranta generala .....	22
1.2 Siguranta personalului .....	23
1.3 Siguranta electrica .....	23
1.4 Mediu de siguranta .....	25
1.5 Transportation Safety.....	25
<b>2. Informatii produs</b> .....	<b>26</b>
2.1 Descrierea bateriei.....	26
2.2 Modul Baterie .....	26
2.3 Definitii porturi.....	27
2.3.1 Zona de conexiuni.....	27
2.3.2 PORNIRE / OPRIRE.....	27
2.3.3 Porturi de comunicare.....	28
2.3.4 Definitii indicatoare LED.....	29
2.4 Instalare.....	29
<b>3. Intretinere</b> .....	<b>37</b>

**Please read this manual before using the product.**

*This user manual introduces the energy storage module in terms of its installation, electrical connections, operation, commissioning, maintenance, and troubleshooting. Please read through the manual carefully before installing and using the energy storage module, and keep the manual for future reference.*

### Application Model

Powerhill LV5K-100-B - PDU  
Powerhill LV5K-100-B - Battery Module

### Applicable Personnel

This user manual is intended for photovoltaic (PV) inverter operating personnel and qualified electrical technicians.

### NOTE!

*This user manual is subject to change without prior notice.*

### Package Contents

#### Battery Module

No.	Item	Used for	Quantity
1	Battery module	Battery module	1
2	2g moisture-proof desiccant	Moisture-proof	2
3	Positioning pin	Used for positioning multiple packs	4
4	Fixing plate	Wall hanging bracket	1
5	Wall pendant	Wall hanging bracket	1
6	Philips Hexagon screw	To fix the fixing plate	4
7	304 stainless steel wall plug	To fix the wall hanging bracket	2

## PDU

No.	Item	Used for	Quantity
1	The base	To put at the bottom of the battery	1
2	The top	Install at the top of the battery	1
3	Foot	Used for positioning multiple packs	4
4	Expansion screw	To fix the support frame	2
5	Cross shaped hexagonal three combination screw	Lock base L parallel machine fixing plate	1
6	Cross shaped hexagonal three combination screw	To fix the fixing plate	2
7	Fixing plate	Wall hanging bracket	1
8	Wall pendant	Wall hanging bracket	1
9	Positioning pin	Used for position multiple packs	4
10	Grounding cable	Used for the grounding	1
11	Communication network cable	One parallel cable and one communication cable	2
12	Red power line	Red power line	1
13	Black power line	Black power line	1
14	RJ45 waterproof body		2
15	Waterproof cover	Combiner box communication waterproof cover	2
16	Screws for waterproof cover		16
17	Red Battery connector	For parallel connection	1
18	Black Battery connector	For parallel connection	1



## 1 Safety Information

### 1.1 General Safety

Please carefully read the manual safety precautions, and observe all the safety instructions on the equipment and in this document.

The “DANGER”, “WARNING”, and “NOTICE” statements in this document do not cover all the safety instructions. They are only supplements to the safety instructions.

For user safety and utilization efficiency of this manual, a list of symbols are designed to alert people from danger. You must understand and comply with the emphasized information to avoid personal injury and property damage. Relative safety symbols have been listed below

	DANGER indicates a hazardous situation which, if not avoided will result in serious injury and
	WARNING indicates a hazardous situation which, if not avoided will result in property loss or void warranty.
<b>NOTE!</b>	<b>NOTE!</b> indicates normal situation which, if not avoided will result in that battery doesn't work.

### NOTE!

Follow local laws and regulations when installing, operating, or maintaining the equipment. The safety instructions in this document are only supplements to local laws and regulations.

## 1.2 Personal Safety

### Personal Requirements

Personnel who plan to install or maintain battery equipment must be trained, understood all necessary safety precautions, and be able to perform all operations correctly.

Only qualified professionals or trained personnel are allowed to install, operate, and maintain the equipment.



#### **DANGER**

- Keep the batteries away from children and pets.
- Do not touch the energized battery, the temperature of the battery enclosure may increase during operation.
- Do not touch the energized battery terminals.
- Do not stand on, lean on, or sit on the battery.

## 1.3 Electrical Safety

### Symbols on battery

There are some electrical symbols on battery relate to electrical safety. Please make sure you have fully understand them before installation.

	Electrical danger	Voltage exists when the battery is powered on. Only qualified engineers are allowed to operate.
	Earth connector	Earth connection
	DC positive and negative connect	Identify positive and negative connectors of DC power
	CE mark	The product meets CE certification
	WEEEtag	This product cannot be thrown away as household waste
	Recycle	Battery can be recycled

## NOTE!

- Please use dedicated insulated tools for installation and maintenance.
- Please check the LED status indicator when the battery is powered on.
- Please ensure the communication cable is connected correctly between the battery and the inverter.
- Please check for inverter alarms and the Charge level reading once communication is established between the inverter and the battery.

### 1.4 Environment Safety



#### WARNING

- Ensure that the equipment is installed in a dry and well-ventilated environment.
- The installation position must be away from direct sunlight and rain.
- The installation position must be far away from fire sources.
- The installation position must be far away from all sources of water.
- The bracket must be installed solid and horizontal.
- Do not expose the equipment to flammable or explosive gas or smoke.
- Do not perform any operation on the equipment in such environments.
- The operation and service life of the battery depend on the operating temperature. Operate the battery at a temperature equal to or better than the ambient temperature. The recommended operating temperature ranges from 0°C to 30°C.

### 1.5 Transportation Safety



#### WARNING

- The products have passed UN38.3 certification.
- The products have MSDS documents available.
- The products belong to class 9 dangerous goods.
- Please protect the packing case from the below situations:
  - Being dampened by rains, snow, falling into water.
  - Falling or mechanical impact.
  - Being upside-down or tilted.



## **DANGER**

- Before installation, ensure that the equipment is intact. Otherwise, electric shocks or fire may occur.
- Do not connect or disconnect power cables while the battery is powered on, as this may cause electric arcs, sparks, fire, or even personal injury.
- Before connecting a power cable, check the positive or negative connectors are correct.
- Do not connect the batteries in series.
- Do not connect battery with AC directly.
- Do not connect battery with PV wiring directly.
- Do not connect the battery with different batteries in parallel.
- Do not connect battery to faulty or unqualified inverter or charger.
- Do not create short circuits with the external connection.
- Make sure the grid is cut off and the battery is powered off before maintenance.
- Make sure the earth cable is connected correctly before operation.



## **WARNING**

- Recharge the battery in every six months if not in use.
- Recharge battery within 10 days after battery is fully discharged.
- Ensure the battery cable is installed correctly.
- When the battery is being installed or repaired, ensure the battery is powered off and and isolated. Using a multimeter check to ensure there is no voltage in the positive and negative terminals.

## 2 Product Information

### 2.1 Battery Overview

The battery is a low-voltage battery storage system which consists of long span LiFePO<sub>4</sub> battery cells and functional BMS. It can store and release electric energy based on the requirements of the inverter controller. It is mainly for home energy storage system.

#### Features

- LiFePO<sub>4</sub> prismatic cell.
- 6000 cycles @25°C , 0.5C, 80% DOD.
- Scalability up to 5 pcs
- Scalable up to 4 systems with 20 battery modules to 102.4 KWh
- Protective and active BMS allows greater reliability and control
- IP 65 grade
- Fire suppression module built-in
- Remote Assistance
- Connectors built-in design
- Fully recyclable at the end of life
- Compact

### 2.2 Battery Module

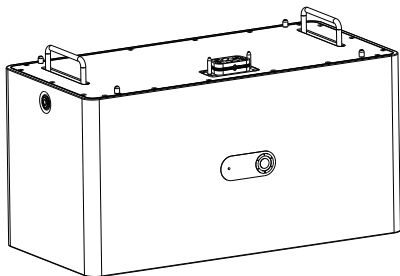

## 2.3 Port definitions

### 2.3.1 Connection Area

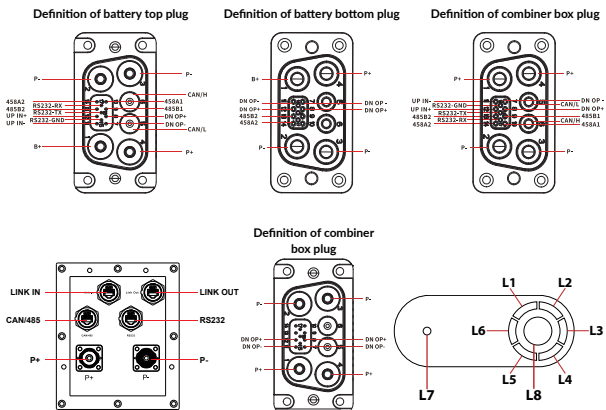

### 2.3.2 ON/OFF

#### 1 ON

For single Battery Module, long press (more than 3 seconds) ON/OFF button, the Normal LED indicator on the front panel will flash, then the battery will operate normally. L1 to L6 show battery Charge level, L7/L8 shows battery status.

For multiple Battery Modules in parallel, long press (more than 3 seconds) ON/OFF button of MASTER battery (which is connected to the inverter), the Normal LED indicator will flash, then the battery system will automatically encode and assign ID to each slave battery and the battery system will operate normally.

#### NOTE!

For multiple batteries in parallel, only the LED State of Charge indicator of the Master battery will flash to show the Charge level level of the whole system, and the LED State of Charge indicators of the slave batteries will turn off, while the Normal&Alarm LED indicators will operate normally.

## 2 OFF

Press ON/OFF button of the Master PACK (which is connected to the inverter) for more than 3s, the LED indicator on the front panel will flash, and then release the button, the master pack will shut down after all the slave packs shut down (Sleep Mode).

For single Battery Module, long press (more than 3 seconds) ON/OFF button, the LED indicator on the front panel will flash, and then release the button, the battery will shut down.

For the system connected with inverter, there is an air switch between the inverter and battery system, normally the air switch keeps off-state if the system does not work.

### 2.3.3 Link Communication Port

RJ45 port supports CAN / RS485 / RS232 communication protocol. CAN/RS485 communication terminal (RJ45 port) connects to the inverter and follows CAN / RS485 protocol.

RS232 communication terminal (RJ45 port) follows RS232 protocol, for manufacturer or professional engineer to debug or service.

CAN/485	
PIN	Definition
Pin 1	RS485-B
Pin 2	RS485-A
Pin 3	/
Pin 4	CAN-H
Pin 5	CAN-L
Pin 6	/
Pin 7	RS485-A
Pin 8	RS485-B

RS232	
PIN	Definition
Pin 6	RS232_RX
Pin 7	RS232_GND
Pin 8	RS232_TX

LINK IN	
PIN	Definition
Pin 2	485A2
Pin 3	485B2
Pin 4	UP IN+
Pin 5	UP IN-

LINK OUT	
PIN	Definition
Pin 2	485A2
Pin 3	485B2
Pin 4	DF OP+
Pin 5	DF OP

## 2.3.4 Indicator Definition



flash 1 - 0.25s on/3.75s off

flash 2 - 0.5s on/ 0.5s off

flash 3 - 0.5s on/ 1.5s off

### LED Indicators Definitions

State	Normal/alarm/ protection	RUN	ALM	Power charge level (LED indicator)						Instruction
		●	●	●	●	●	●	●	●	
Shut down	Sleep	off	off	off	off	off	off	off	off	All off
Standby	Normal	Flash1	off	According to battery indicator						Standby state
	Alarm	Flash1	flash3	According to battery indicator						Module of low voltage
Charging	Normal	on normally	off	According to battery indicator(Battery indicator maximum LED flash 2)						Maximum power LED flash (2),
	Alarm	on normally	flash3	According to battery indicator						
	Overcharge protection	on normally	off	On normally	on normally	on normally	on normally	on normally	on normally	If there is no mains supply, the indicator is in standby state
	Temperature, over current, fail-safe protection	off	on normally	off	off	off	off	off	off	Stop charging
Discharging	Normal	flash3	off	According to battery indicator						
	Alarm	flash3	flash3	According to battery indicator						
	Under-voltage protection	off	off	off	off	off	off	off	off	Stop discharging
	Temperature, over current, short-circuit, reverse connection, fail-safe protection	off	on normally	off	off	off	off	off	off	Stop discharging
Failure		off	on normally	off	off	off	off	off	off	Stop charging and discharging

## 2.4 Installation

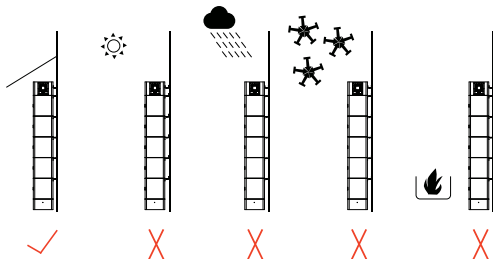

### Step 1

Place the base against the wall, the distance between the base and the wall is 30mm as followed.

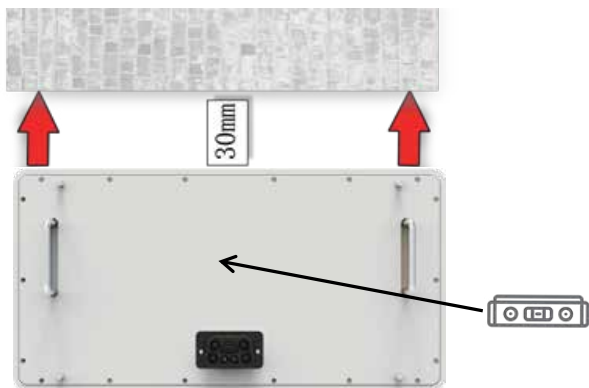

### NOTE!

*Levelness of the base is less than 2mm*

### Step 2

Screw the foot cup into the base, then place the first battery pack on the base.

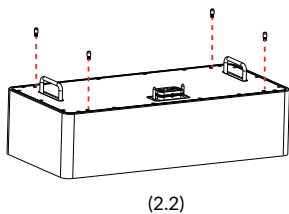
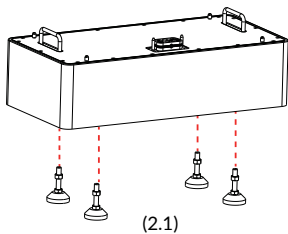

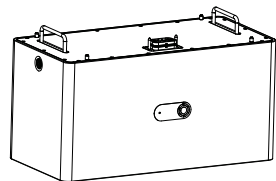

(2.3)

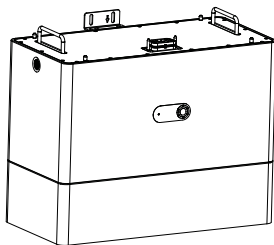

(2.4)

### Step 3

Screw the foot cup into the base, then place the first battery pack on the base.

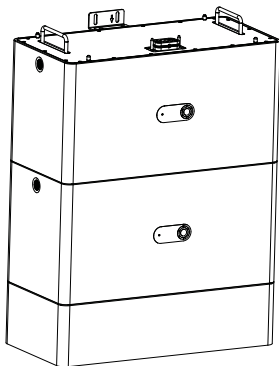

(3.1)



(3.2)

#### Step 4

Place the combiner box on top of the last battery and then install the dust cover.

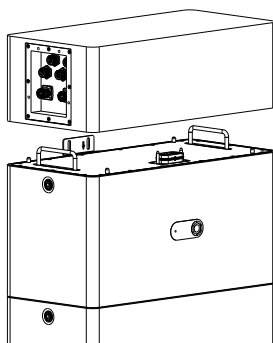

(4.1)

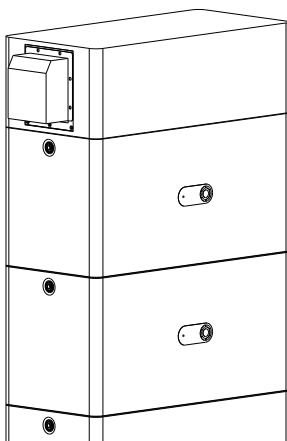

(4.2)

### Step 5

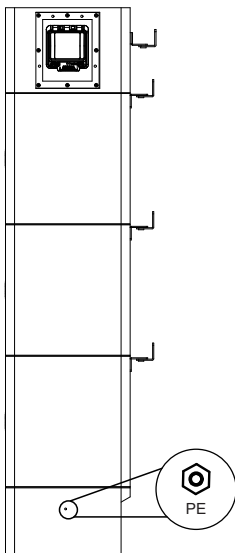

Carefully align the wall bracket with the backplate on the Controller, and secure it in place.



### Step 6

1. Load power exceeding 5kW requires at least 2 layers of stacking.
2. The maximum number of stacking layers is 5 and the maximum output power is 10kW. The power of the inverter selected for the battery module must be less than the maximum output power of the battery module.

Stacking layers	Load power
1 layer	5kW
2-5 layers	5-10kW

 <b>Danger</b>	<p>Ensure power cables are installed with the correct polarity. A dangerous situation may arise if the polarities are reversed.</p>
 <b>Danger</b>	<p>Do not create a short circuit between the positive and negative terminals of the battery. Ensure the polarity is correct during installation.</p>
 <b>Warning</b>	<p>Incorrect communication cable connection will cause the battery system to operate in unexpected ways which may lead to system failure.</p>

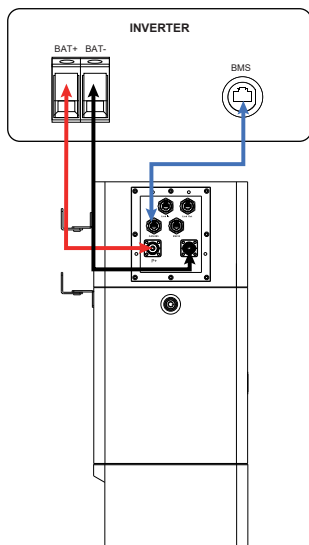

**NOTE!**  
 1-layer wiring method

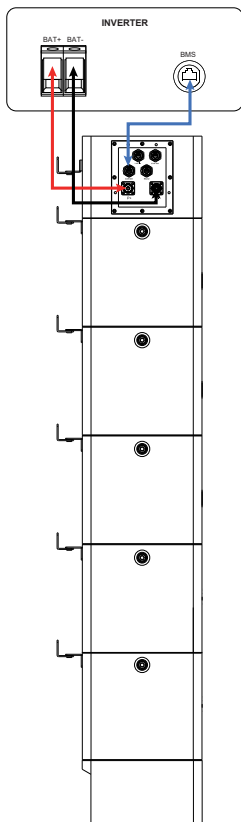

**NOTE!**

2 to 5 layer wiring method.

The number of layers in the middle is omitted.

When using an inverter of 10kW or above, the positive and negative ports of each battery must be connected in the wiring method shown in the figure below. In order to ensure equal current flow, the length of the two positive and negative poles connecting lines must be the same.)

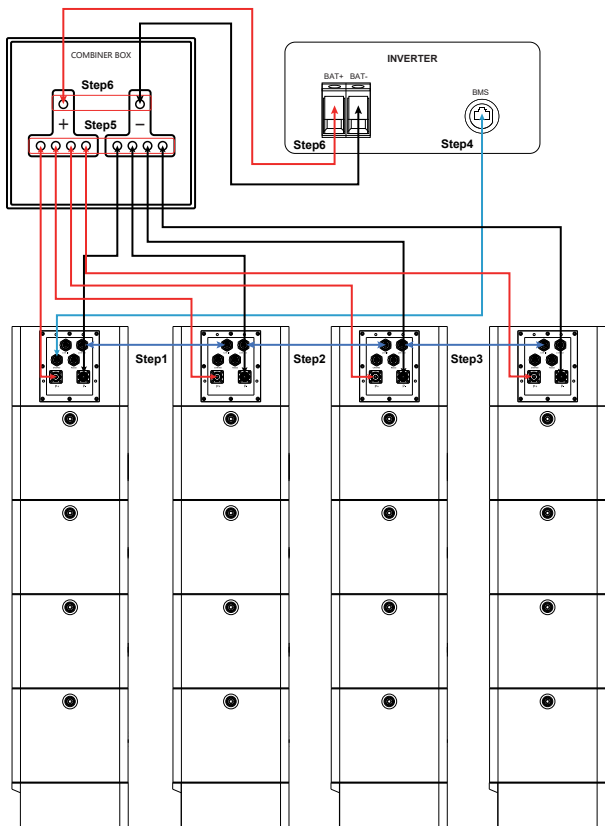

### 3 Maintenance

- Recharge Requirements During Normal Storage.

Battery should be stored in an environment with temperature range between  $-10^{\circ}\text{C} \sim +45^{\circ}\text{C}$  and maintained regularly according to following table with 0.5C current till 50% Charge level after long storage time.

Storage Environment Temperature	Relative Humidity of Storage Environment	Storage Time	Charge level
Below $-10^{\circ}\text{C}$	/	Prohibit	/
$-10 \sim 25^{\circ}\text{C}$	5%-70%	$\leq 12$ months	Charge level $\geq 60\%$
$-25 \sim 35^{\circ}\text{C}$	5%-70%	$\leq 6$ months	Charge level $\geq 60\%$
$35 \sim 45^{\circ}\text{C}$	5%-70%	$\leq 3$ months	Charge level $\geq 60\%$
Above $45^{\circ}\text{C}$	/	Prohibit	/

- Recharge Requirements When Over Discharged

Over discharged (90%DOD) battery should be recharged according to following table, otherwise over discharged battery will be damaged.

Storage Environment Temperature	Storage Time	Note
$-10 \sim 25^{\circ}\text{C}$	$\leq 15$ days	Battery Pack disconnected to inverter
$-25 \sim 35^{\circ}\text{C}$	$\leq 7$ days	
$35 \sim 45^{\circ}\text{C}$	$\leq 12$ hours	Battery Pack connected to inverter



## Disposal of Old Electrical & Electronic Equipment

*(Applicable in the European Union and other European countries with separate collection systems)*

This symbol on the product or on its packaging indicates that this product shall not be treated as household waste.

Instead it shall be handed over to the applicable collection point for the recycling of electrical and electronic equipment.

By ensuring this product is disposed of correctly, you will help prevent potential negative consequences for the environment and human health, which could otherwise be caused by inappropriate waste handling of this product.

The recycling of materials will help to conserve natural resources.